

***POWERAMP***<sup>®</sup>

**E SERIES HYDRAULIC  
OWNER'S AND OPERATIONS  
MANUAL**

**SYSTEMS, INC.  
P.O. BOX 309  
Germantown, WI 53022  
Phone 414-255-1510  
Fax 414-255-4199**

11/96

# TABLE OF CONTENTS

Safety ..... 1

Introduction ..... 2

Preparation ..... 2

Installation ..... 3-6

Adjustment and Testing ..... 7-8

Operation ..... 9

Operating Instructions ..... 10

Preventive Maintenance ..... 11-13

# INTRODUCTION

---

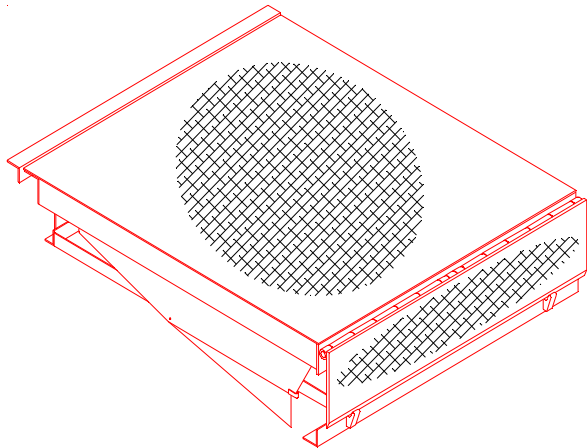

Congratulations on your choice of Poweramp docklevelers. Your manual covers the standard E Series series hydraulic docklevelers.

Designed by Poweramp to be a marvel of simplicity and efficiency, your dockleveler, when properly installed will provide many years of trouble-free performance with an absolute minimum of maintenance. It's revolutionary hydraulic system efficiently controls and operates every function. To obtain maximum performance and longest possible use, a simple program of preventative maintenance is recommended.

The E Series control assembly allows pushbutton operation of the dockleveler functions. Each unit has been factory pre-wired and tested to insure satisfactory operation.

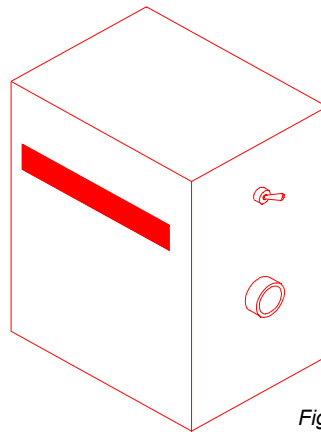

Figure 2

Electrical drawings are included with each unit to illustrate which connections are to be made in the field. Once again, thank you and congratulations on your purchase of a Poweramp hydraulic dockleveler.

# PREPARATION

## WARNING

Barricade the work area to prevent unauthorized use of the unit before installation has been completed.

## WARNING

Be sure power supply circuit is opened at main service box or circuit breaker box prior to electrical installation. Failure to disconnect power supply could result in equipment damage and/or personal injury or death.

## CAUTION

Have all electrical work performed only by qualified electricians.

## WARNING

Do not ground welding equipment to any hydraulic or electrical components of the unit.

Do not make any final electrical connections until all welding is complete.

All welding required for installation is at the frame of the unit. Always ground to the frame to prevent possibility of hydraulic or electric component failure. Failure to follow these warnings could result in injury or

1. Remove all debris from pit and sweep out.
2. Check entire dockleveler pit for proper construction according to approved/certified pit drawings. Check to be sure that pit walls are square and plumb. Check electrical service to the pit to assure it agrees with the correct location for the junction box.

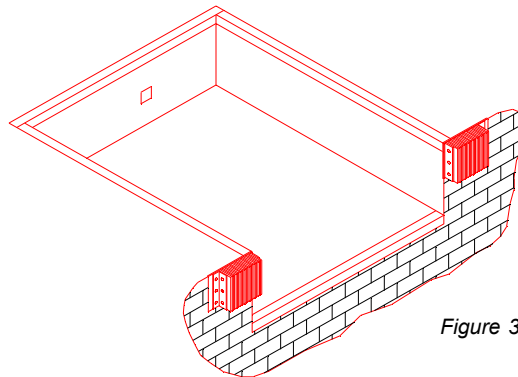

Figure 3

3. If conduit must be installed (replacing an existing mechanical dockleveler) do so at this time. Refer to the conduit requirements on the pit detail sheet. Follow all applicable electrical codes and standards.
4. Some units are shipped with the bumpers and control assembly banded to the frame of the dockleveler. Remove these items from the frame at this time. DO NOT remove the shipping bands around the frame and platform at this time. Some units are shipped with 2 x 4's attached to the frame. The 2 x 4's must be removed before the unit is placed in the pit.
5. Mount the control assembly and wire at this time. Refer to the electrical drawings provided to determine required field connections.

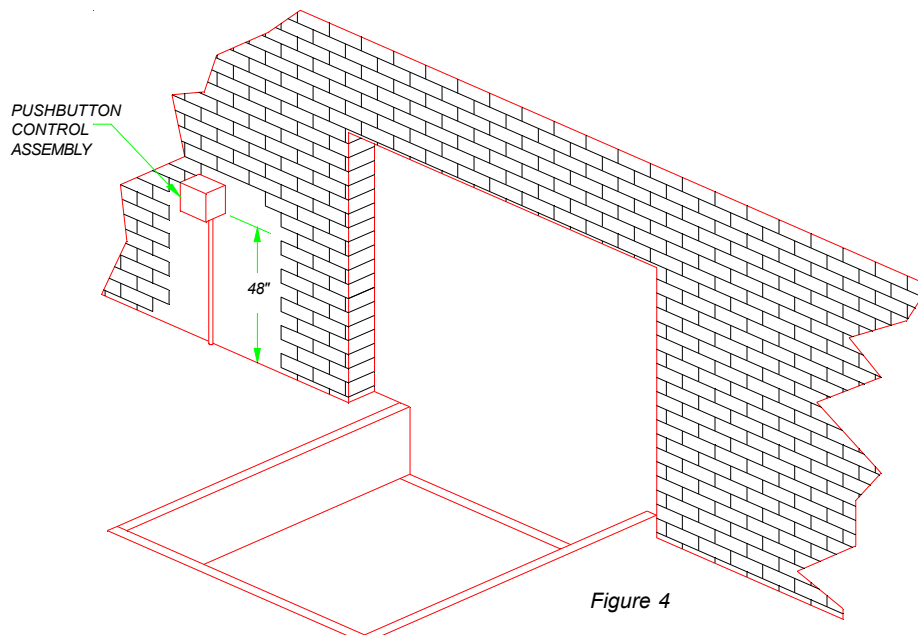

Figure 4

# INSTALLATION

Poweramp docklevelers are designed with installation in mind. Each unit is shipped with lifting lugs bolted thru the outboard joists. The lifting lugs should be used whenever lowering or lifting a dockleveler into or out of a pit.

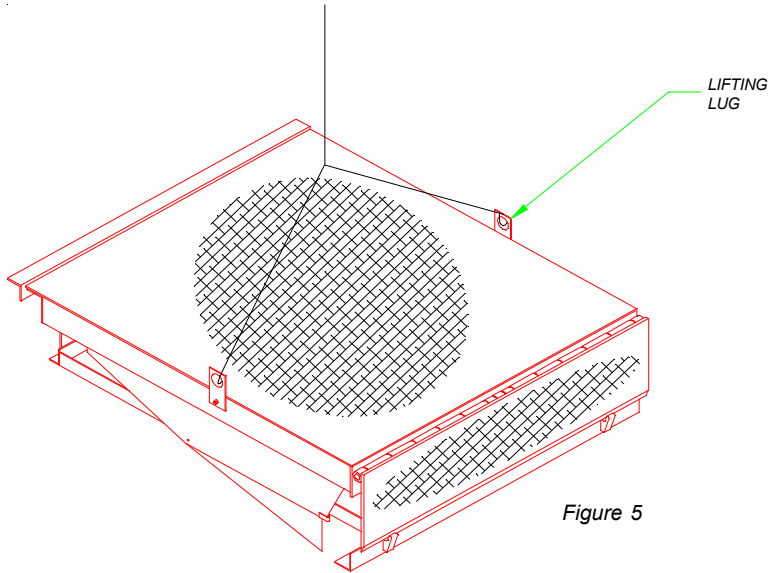

Figure 5

To allow for inconsistent pits, Poweramp docklevelers are designed with a nominal 3/4" shimming distance. Shims are to be located under each of the 3 rear vertical supports. Also place shims under the 2 lip keeper/cross traffic supports, hoist cylinder trunnion supports and under the maintenance prop.

1. Place shims on the pit floor in the locations shown. Continue to stack shims until the dimension from the top of the shims to the dock floor matches the dockleveler height. A string line may be stretched across the pit opening over the shims so an accurate measurement can be taken. (See Figure 7).

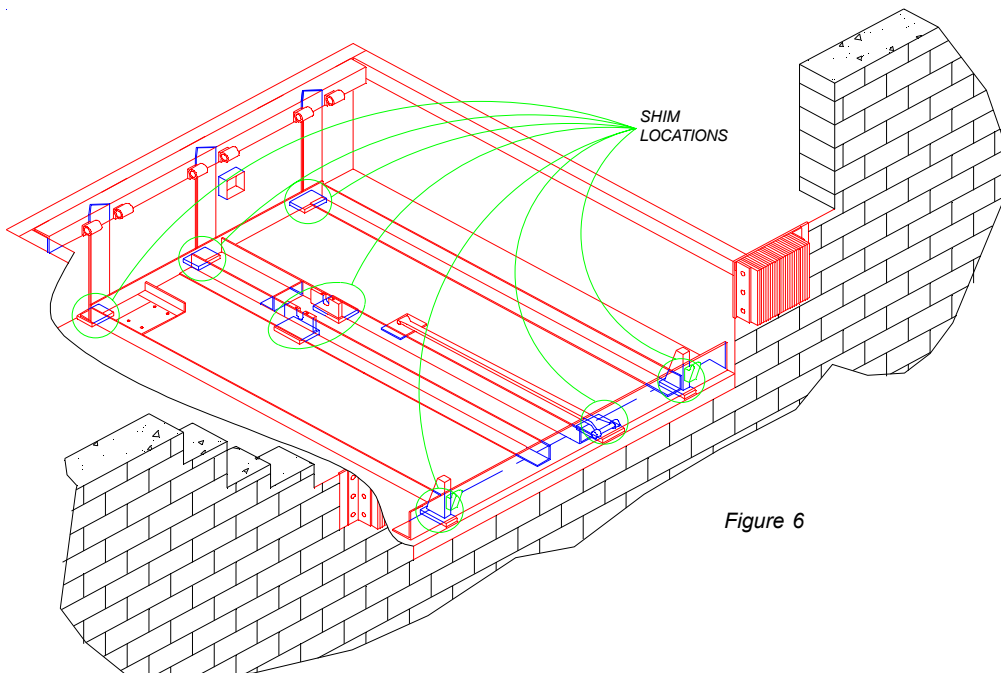

Figure 6



## WARNING

Do not grind or weld if hydraulic fluid or other flammable liquids are present. Always keep a fire extinguisher of the proper type nearby.

# INSTALLATION

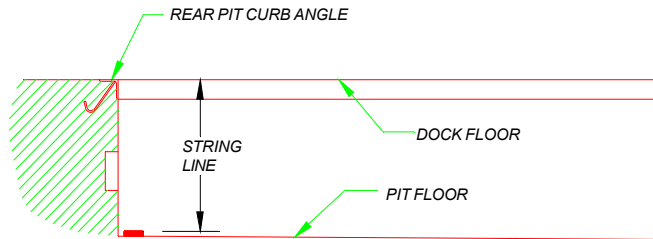

Figure 7

2. Remove the stacks of shims and weld to the dockleveler frame directly beneath the corresponding vertical support.

3. Position the dockleveler in the pit. The rear edge of the dockleveler must be tight against the rear pit curb angle.
4. Use 1/4" thick shims to shim the front of the dockleveler. Shims are to be placed under the 2 lip keeper/cross traffic supports and under the maintenance prop pivot point. To determine the correct number of shims, position the dockleveler so that it is level with the dock floor.
5. With the front shims in place, check to insure that a smooth transition exists between the dock floor and dockleveler. Add or remove shims as required to achieve this condition.
6. Check alignment of dockleveler with the pit. If the pit conforms to the certified pit drawings, there will be a 1/4" gap between the ends of the upper frame angle and the side curb steel. There should also be a 1" gap between the leveler platform and pit sides (see figure 8).

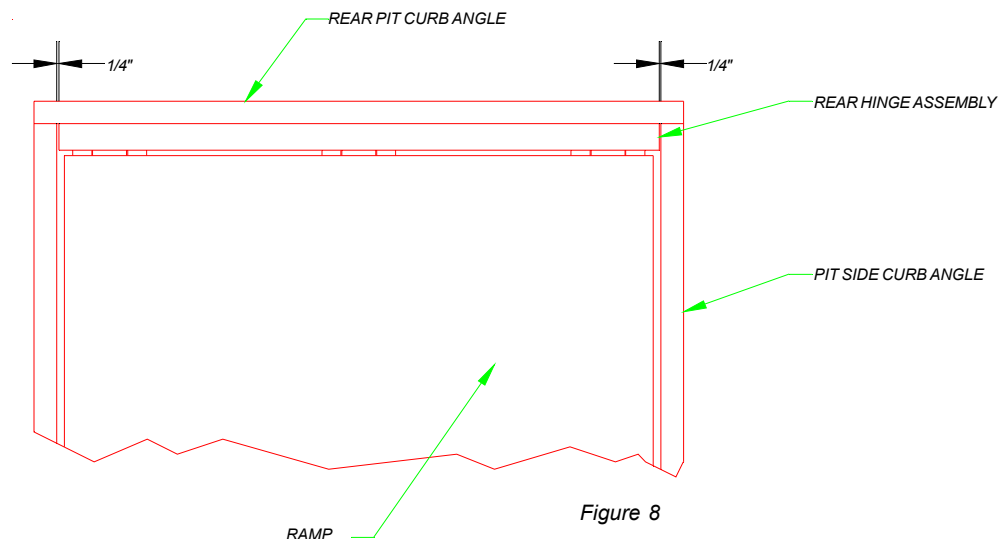

Figure 8

7. With the rear frame upper angle tightly against the curb steel, weld the rear frame upper angle to the rear curb angle in the pattern for the width of the dockleveler being installed. Note: weld pattern will vary based on dockleveler width. Figure 9 illustrates a typical weld pattern.

# INSTALLATION

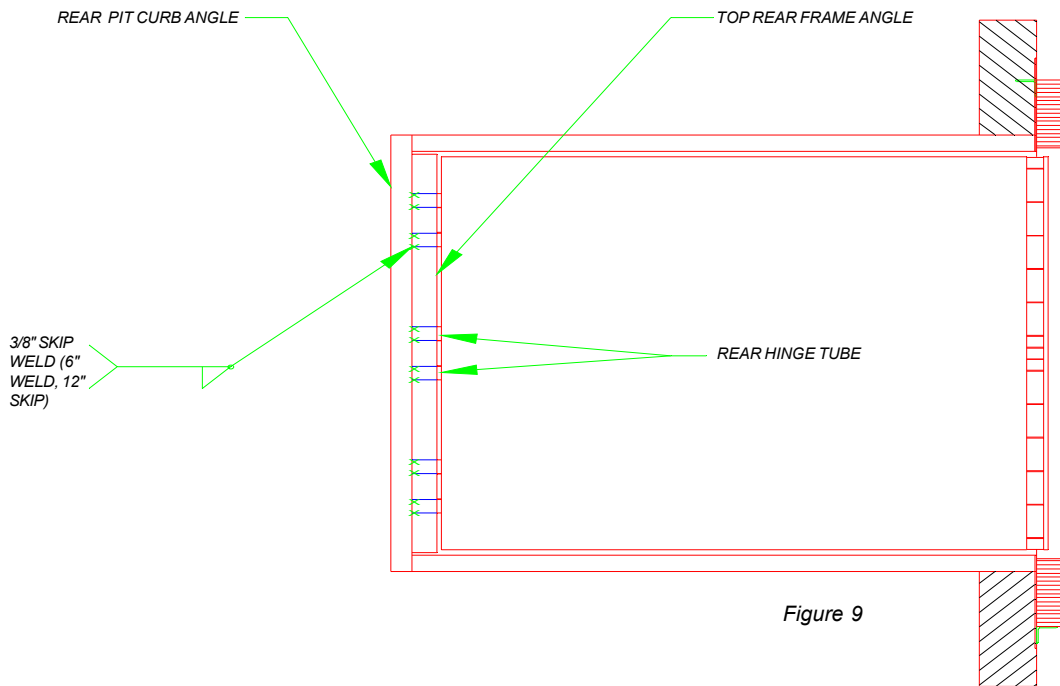

Figure 9

8. With the rear angle welded in place, cut and remove the shipping bands.
9. Raise the platform by external means (crane or fork truck) and place maintenance prop in position to support platform. Be sure shims are located between prop attachment point to the frame and pit floor before supporting platform with maintenance prop.
10. Weld shims in place under front edge of dockleveler. Position shims so that fillet welds can be used to secure shims. Weld shims in place under rear vertical supports if not done previously.
11. With the dockleveler safely supported by the maintenance prop and the frame shims welded in place, position shims to support the hoist cylinder trunnion. Both sides of the hoist cylinder trunnions must be solidly shimmed for their entire length. When positioning the shims, always check to make sure the hoist cylinder trunnion is level from side to side as well as from front to back. Once the required shims have been positioned, weld in place using fillet welds.
12. With the welding complete, the power cable can now be connected to the field wires in the pit junction box.
13. After all of the electrical connection in the pit have been made, use the lifting lugs to again lower the dockleveler off the maintenance prop. Remove lifting chains or sling from lifting lugs.
14. Check to be sure the leveler is flush with dock floor and that the lip contacts both lip keepers evenly.



## WARNING

Be sure to securely block platform in raised position before entering pit to weld shims. Do not use maintenance prop to support raised platform until shims have been welded beneath maintenance prop support plate.



## WARNING

Be sure power supply circuit is opened at main service box or circuit breaker box prior to electrical installation. Failure to disconnect power supply could result in equipment damage and/or personal injury or death.

## CAUTION

Have all electrical work performed only by qualified electricians.



## WARNING

Always barricade the work area to prevent unauthorized use of the unit before maintenance is complete.

Always lock off all electrical disconnects after raising platform and setting maintenance prop when service under the unit is required. More than one electrical disconnect switch may be required to de-energize the equipment.

Always stand clear of the dockleveler lip when working in front of the unit.

15. Depress and hold the raise button until the maintenance prop can be positioned properly. This will require 2 people should a remote raise button be unavailable.
16. With the maintenance prop supporting the platform, remove the lifting lugs.
17. Depress the raise button again until you hear the maintenance prop return to its stored position.
18. Cycle the dockleveler 4 or 5 times throughout its complete operating range to assure proper operation.
19. Install bumpers.

# ADJUSTMENT AND TESTING

While you were cycling the dockleveler upon completion of the installation, you should have noticed that the dockleveler would raise to a certain point after which time the lip would extend. Releasing the raise button would allow the dockleveler to lower to the full below dock position after which the lip would fold. Pressing the raise button would then cause the dockleveler to raise. When the lip cleared the keepers, the raise button could be released and the dockleveler would rest in the cross traffic (stored) position. If this operation was not apparent, one of three adjustments may be required:

1. If the dockleveler did not raise but pump/motor was running, the main pressure relief may need adjustment. Pressure relief can be found in the steel block that connects the reservoir to the motor.

The adjustment is an allen wrench adjustment located directly beneath a hex plug on the side of the block. Remove the hex plug to access the allen screw. Turning the screw clockwise will increase the pressure. Remember, if you have a 3 phase power source, the motor may be running backwards.

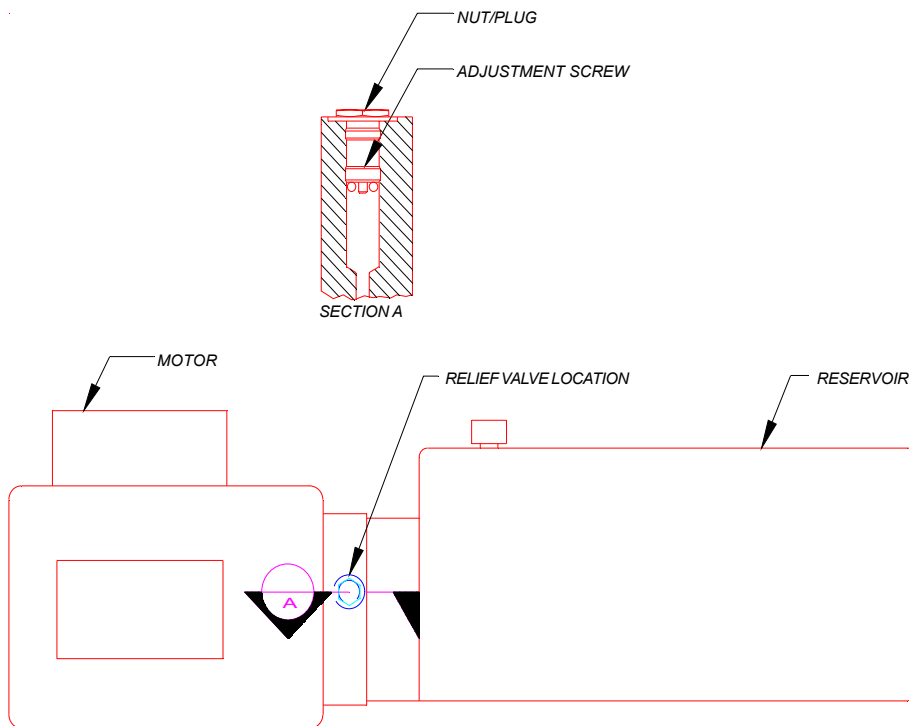

Figure 10

## ADJUSTMENT AND TESTING

If the dockleveler lip did not extend, or extended too early, the cable weight may need adjusting. The cable weight is located underneath the dockleveler directly behind the valve block. As the platform raises, the cable moves the valve lever. When the cable force exceeds the force necessary to shift the valve spool, the spool shifts causing the oil to flow to the lip cylinder. The factory setting will result in the lip extending with approximately 1" of travel left in the hoist cylinder. Sliding the weight up the cable will result in the lip extending earlier. Be sure to tighten the weight down securely to the cable to avoid the weight from sliding on the cable.

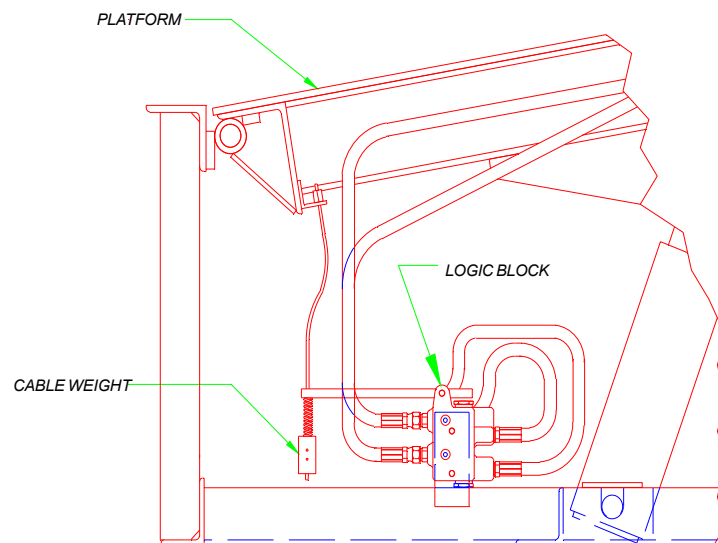

Figure 11

If the dockleveler did not lower, it is possible that the speed control requires adjustment. The speed control is located in the logic block. It is an allen wrench adjustment located in the casting directly behind the upper front hose connection. Clockwise adjustments will slow the lowering speed of the dockleveler. To avoid stops while the dockleveler is lowering, the speed of the dockleveler should be decreased.

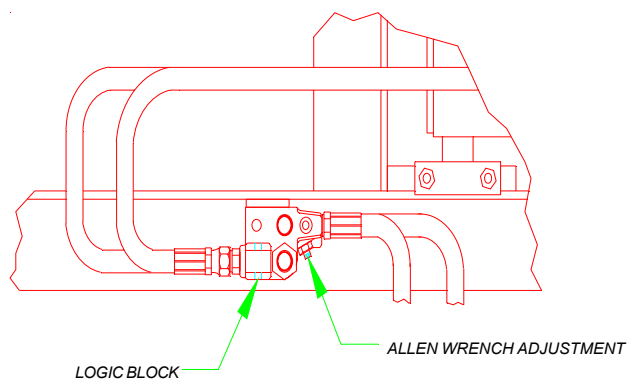

Figure 12

# ADJUSTMENT AND TESTING

Your dock leveler may be equipped with Auto Return to Dock. Auto Return to Dock is an operation available on E Series dock levelers that will automatically reposition the dock leveler into the stored, cross traffic position after the truck departs. This option utilizes a switch under the dock leveler and a target fastened to the lip. See Figure 13.

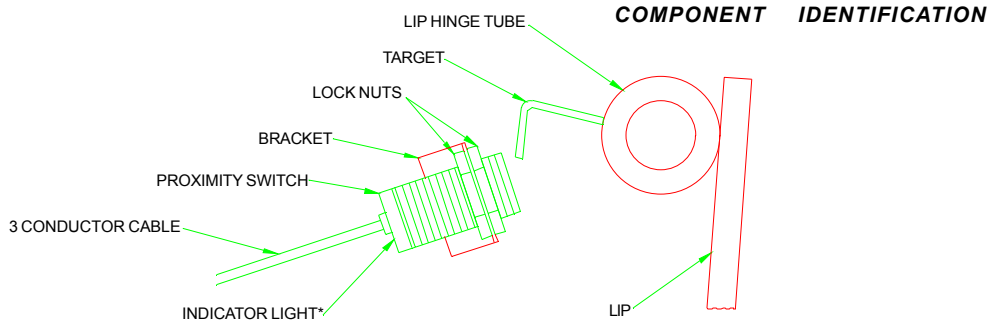

Figure 13

Typical factory settings for dimensions "A" & "B" are approximately 1" & 1/4" respectively. The values for dimensions "A" & "B" for this application may be different than the typical factory settings. The switch and/or target are to be adjusted to obtain the results indicated in figures 3A through 3C below. Dimension "A" can be changed by bending the target. Dimension "B" can be changed by moving the switch in the bracket.

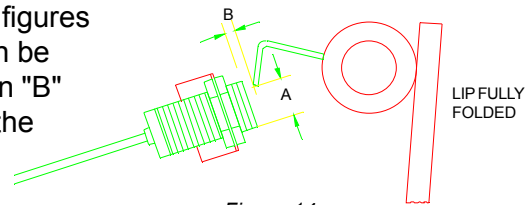

Figure 14

**IMPORTANT:** Work lip by hand when making adjustments to make sure that the target does not make contact with switch. Damage to switch will occur if target contact switch.

**IMPORTANT:** Maximum tightening torque for lock nuts is 27 N-m (20 FT-LBS). Damage to switch will occur if maximum tightening torque is exceeded.

\* Figure 13 shows the indicator light at the back end of the housing. Some switches have the light in the side of the housing.

# ADJUSTMENT AND TESTING

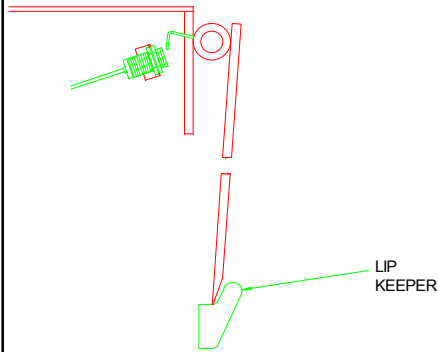

Dock Leveler at cross traffic position. Lip fully folded, inside keepers. (Lip also fully folded when leveler on maintenance prop.)

1. Target not in sensing area of switch.
2. Switch "OFF" = open (no signal sent to load).
3. Switch indicator light "OFF".
4. The dock leveler does not automatically raise & return to dock.

Figure 15

Dock leveler at full below dock position. Lip partially extended, outside keepers.

1. Target in sensin area of switch.
2. Switch "ON" = closed (signal sent to load).
3. Switch indicator light "ON".
4. The dock leveler automatically raises, after an approximate 6 second delay, & returns to dock\*\*.

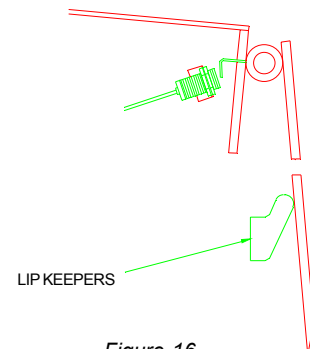

Figure 16

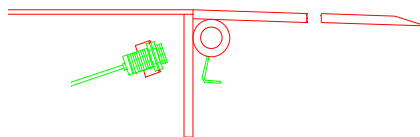

Figure 17

Dock leveler on truck bed. Lip fully extended.

1. Target not in sensing area of switch.
2. Switch "OFF" = open (no signal sent to load).
3. Switch indicator light "OFF".
4. The dock leveler does not automatically raise & return to dock.

\*\*The 6 second delay is in the switch. The dock leveler will raise after approximately 6 seconds after the target is sensed by the switch.

## OPERATION

---

The E Series dockleveler is designed to compensate for +/- 12" of height difference between the loading dock and the truck bed. To position the dockleveler, the operator utilizes the E Series pushbutton controls. When the raise pushbutton is pushed and held, a motor is activated that in turn drives a hydraulic pump which raises the dockleveler platform. Releasing the pushbutton allows the platform to lower.

A cable attached between the platform and valve lever shifts a spool in the hydraulic logic block redirecting the flow of oil to the lip cylinder extending the lip. After fully extending the lip, releasing the pushbutton will allow the dockleveler to lower.

After loading/unloading, the dockleveler can be repositioned to the stored position by depressing and holding the raise pushbutton. As the platform raises, the lip folds to the pendant position. Once the lip clears the truck bed, the raise button can be released allowing the leveler to lower to its level to the stored position.

The E Series Hydraulic dockleveler utilizes hydraulic logic and simple one button operation for ease of use.

# OPERATING INSTRUCTIONS



## WARNING

Do not operate the unit if any personnel are on or in front of the unit.

Do not operate the unit until the truck/trailer is parked squarely against the dock bumpers.

Do not enter the truck/trailer unless:  
1. The dockleveler lip is resting securely on the truck/trailer bed.

Truck/trailer wheels must be chocked if the truck restraint is not utilized.

Failure to follow these instructions could result in serious personal injury or death.

1. Check to make sure truck is positioned squarely against dock bumpers.
2. Instruct the driver to remain at the dock until the loading/unloading process is complete.
3. Chock trailer wheels.
4. If loading dock is equipped with trailer restraint, engage restraint.
5. If required, remove end loads with dockleveler in the cross traffic (stored) position.
6. To extend dockleveler lip onto the trailer:
  - A. Depress and hold the raise pushbutton. The dockleveler platform will raise.
  - B. Shortly before the dockleveler platform reaches its highest position, the lip will extend.
  - C. When the lip is fully extended, release the raise pushbutton.
  - D. The dockleveler will lower resting on the truck bed.
7. Verify that the lip is fully extended and supported by the truck bed along its entire width.
8. Proceed with loading/unloading.
9. When loading/unloading is complete, or to load end loads, return dockleveler to the stored position by:
  - A. Push and hold the raise button. The dockleveler platform will raise. While the platform is raising, the lip will fold.
  - B. Release the raise button when the lip clears the trailer bed. The leveler will lower to the dock level (stored) position.
  - C. Check that the lip is in the keepers. Leveler should be level with dock floor.
10. Unchock trailer wheels and release truck, if it is being restrained.
11. Tell driver that truck may leave.

# PREVENTIVE MAINTENANCE

Maintenance on your E Series Hydraulic dockleveler can be classified as both weekly and monthly.

## WEEKLY MAINTENANCE

1. At least once each week, operate the unit through all of its operating cycles to maintain lubrication.
2. Inspect the dockleveler platform hinge area and lip area. The hinge areas should be kept free of debris and dirt. Build up of foreign material in the hinge areas will cause abnormal operation. NOTE: Position the dockleveler in the full below dock position to thoroughly inspect the platform (rear) hinge area.

## MONTHLY MAINTENANCE

1. Lubricate the unit as shown in figure 13. Failure to properly lubricate the unit will cause abnormal operation of the unit.

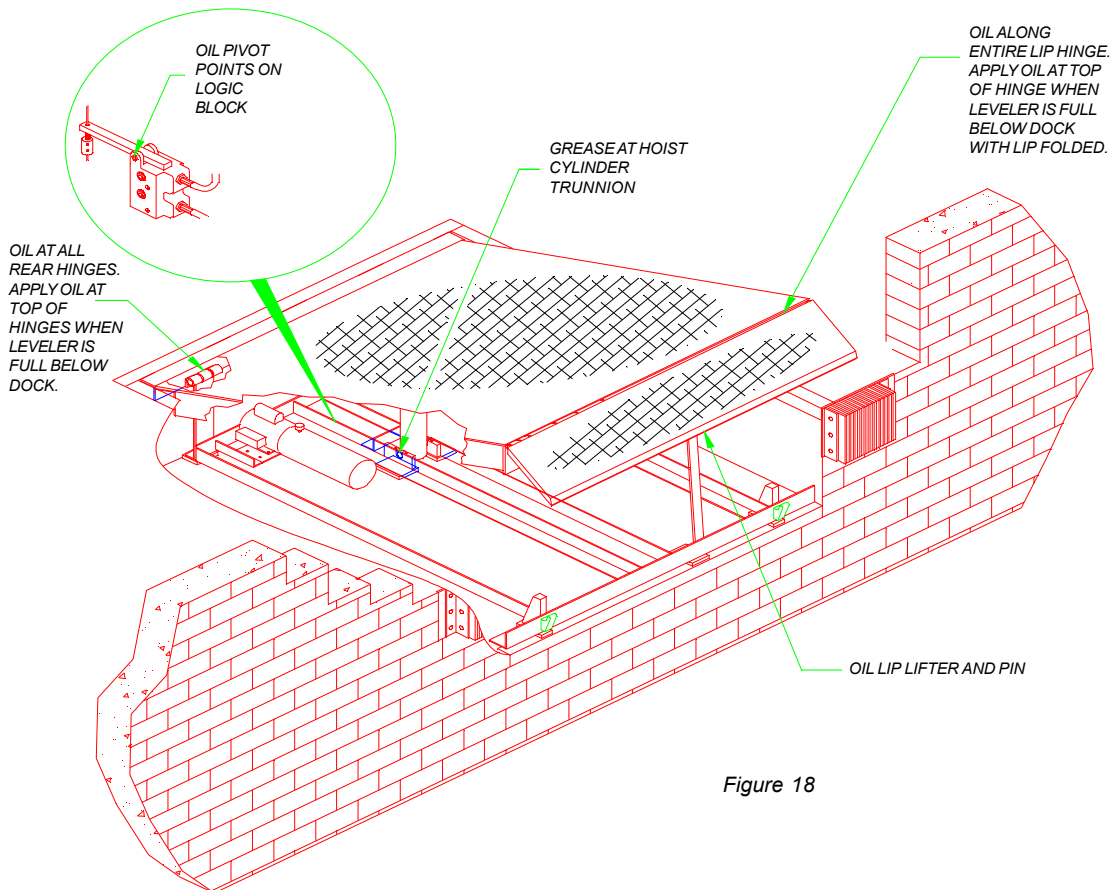

Figure 18

## PREVENTIVE MAINTENANCE

2. Check the hydraulic fluid level in the reservoir of the powerpack (i.e. motor/pump/reservoir) when the dockleveler is safely supported by the maintenance prop. The fluid level should be approximately 2" from the top of the reservoir. A low fluid level or the use of non-recommended fluids will cause abnormal operation of the unit.

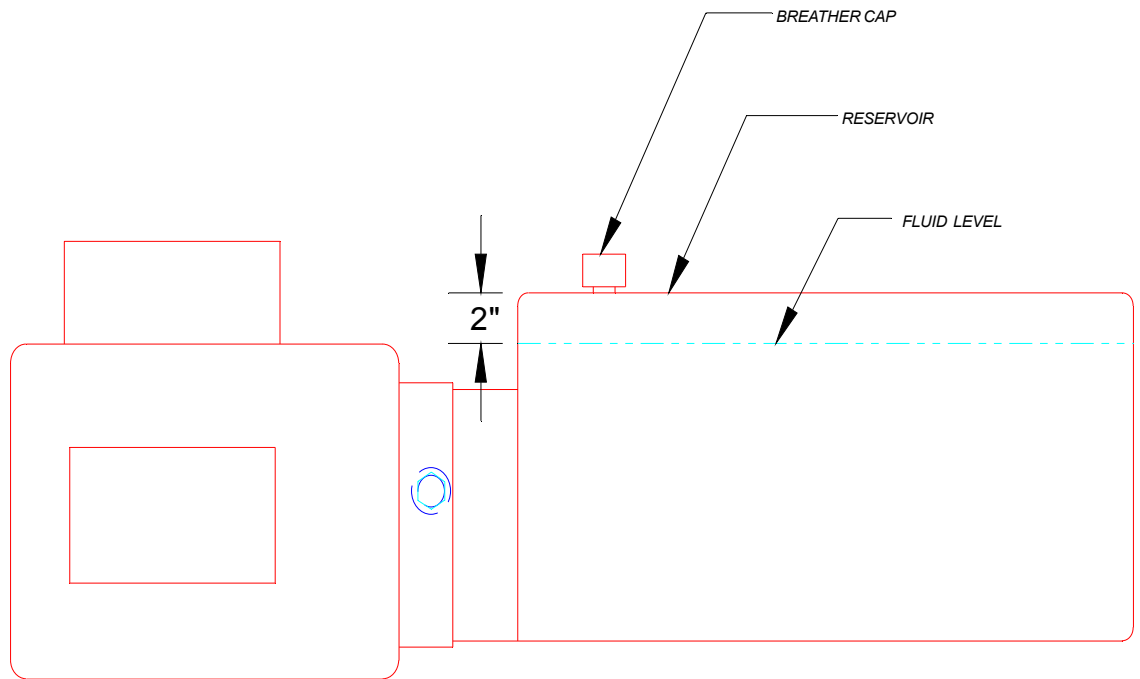

Figure 19

3. When finished checking the fluid level, replace the breather cap and return the leveler to the cross traffic position (the lip folded inside the keepers, with the platform level with the dock floor).

# PREVENTIVE MAINTENANCE

## SERVICING UNDER THE DOCKLEVELER

If the maintenance to be performed requires access to the unit from the pit, support the dockleveler platform and lip with the maintenance prop. Position the prop behind the front header plate of the platform as illustrated in figure 15. Stay clear of the lip. The lip will fold after the platform has rested on the maintenance prop.

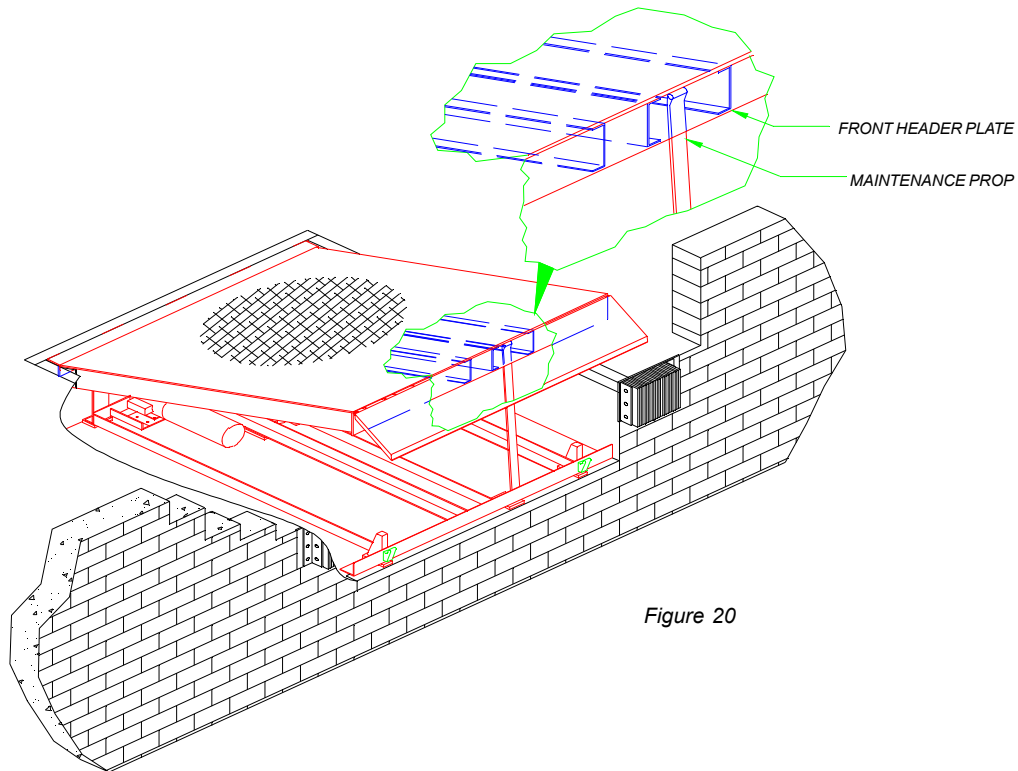

# TROUBLESHOOTING GUIDE



## WARNING

Always barricade the work area to prevent unauthorized use of the unit during repair or maintenance procedures.

Always lock OFF all electrical disconnects when servicing the unit. Always stand clear of the dockleveler lip when working in front of the unit.

Perform the following procedures prior to beginning detailed troubleshooting:

- A. Check all fuses inside the control assembly(s). Replace any bad fuse with one of equivalent specification.
- B. Confirm presence of necessary voltages inside the control assembly(s).

DOCK LEVELER		
PROBLEM	CAUSE(S)	SOLUTION
Leveler does not operate. Motor does not energize.	1. Motor overload device tripped.	1. Reset Overload relay (3 phase) or replace fuse (1 phase). Determine cause of device tripping. NOTE: If replacing fuse, replace with device of equal specifications.
Leveler does not operate. Motor energizes but does not run (motor hums, overload device should trip).	1. 3 phase units only - voltage at one line is absent (motor being single phased).	1A. Fuses at motor branch circuit overcurrent device only - check for tripping fuse. Replace fuse. Determine cause of fuse tripping.
		1B. Check motor starter for component failure. Disconnect wires at load side of starter. Use voltmeter to read lin-to-line voltages at line side and load side of starter. Line side and load side voltage values should be nearly identical. Replace starter if values not identical.
		1C. Check all wiring to motor for high resistance (loose) or no connection.
	2. Replace motor..	
Leveler will not raise. Pump operates in pressure relief.	1. Load on platform.	1. Remove load. Unit is designed to raise no more than its own weight as a safety feature.
Leveler operates slowly.	1. Low hydraulic fluid.	1. Add fluid. See Preventive Maintenance section, page 13.

# TROUBLESHOOTING GUIDE

DOCK LEVELER (Continued)		
PROBLEM	CAUSE(S)	SOLUTION(S)
CONTINUED	2. Pressure relief valve set too low.	2. Locate valve. See Figure 10, page 8. Remove cover nut. Using Allen wrench, turn Allen screw CW approximately 1/2 turn. Check speed. If leveler continues to operate slowly, repeat above. NOTE: The valve set point should NOT be set at a level that will cause the motor operating current to exceed its full load amp value at any time, including when the unit is operating in pressure relief.
	3. Damaged or blocked hydraulic hose(s).	3. Replace damaged hose(s). Remove blockage from hose(s).
Leveler platform does not raise to its full height OR platform raises to full height but lip does not fully extend OR motor overcurrent device and/or overload device continuously tripping.	1. Low hydraulic fluid.	1. Add fluid. See Preventive Maintenance section, page 13.
While leveler is descending, it locks into "safety". Lip drops to vertical position.	1. Platform down-speed is too fast.	1. Slow speed as follows: Loosen jam nut in radius of fluid logic block. Using 1/8" Allen wrench, turn Allen screw CW approximately one full turn; tighten jam nub. Check down-speed. If leveler still descends too rapidly, repeat above. If leveler descends TOO SLOWLY repeat above, BUT turn Allen screw CCW.
Platform reaches full height, but lip does not automatically extend when the pushbutton is pressed.	1. Weight on operating arm cable has slipped down on cable.	1. Loosen setscrews on operating cable weight. DO NOT LOSE steel ball under each screw. Raise weight 1/2" to 3/4" and secure screws. If spring is worn, replace.
Lip extends almost immediately when the pushbutton is pressed. Platform will raise after lip extends.	1. Spool extending through top of logic block stuck ON. Operating arm binding causing arm to prematurely press down on and activate spool.	1. Free-up operating arm. If necessary, detach arm from logic block. Spray WD-40 penetratin goil or equivalent over top of logic block. Work spool to free-up spool. Replace spool if arm not contacting spool and problem persists.
Lip does not extend.	1. Spool extending through top of logic block stuck OFF. Operating arm binding so that arm will not press down on and activate spool.	1. Free-up operating arm and apool. If necessary, detach arm from logic block. Spray WD-40 penetrating oil or equivalent over top of logic block. Work spool to free-up spool.
Units with auto return to dock only. Leveler will not automatically return to cross traffic position.	1. Auto return proximity switch that senses when leveler lip at below dock target and/or switch out of adjustment	1. Locate switch. Adjust switch and/or target so that target is in sensing range of switch when unit is at below dock.

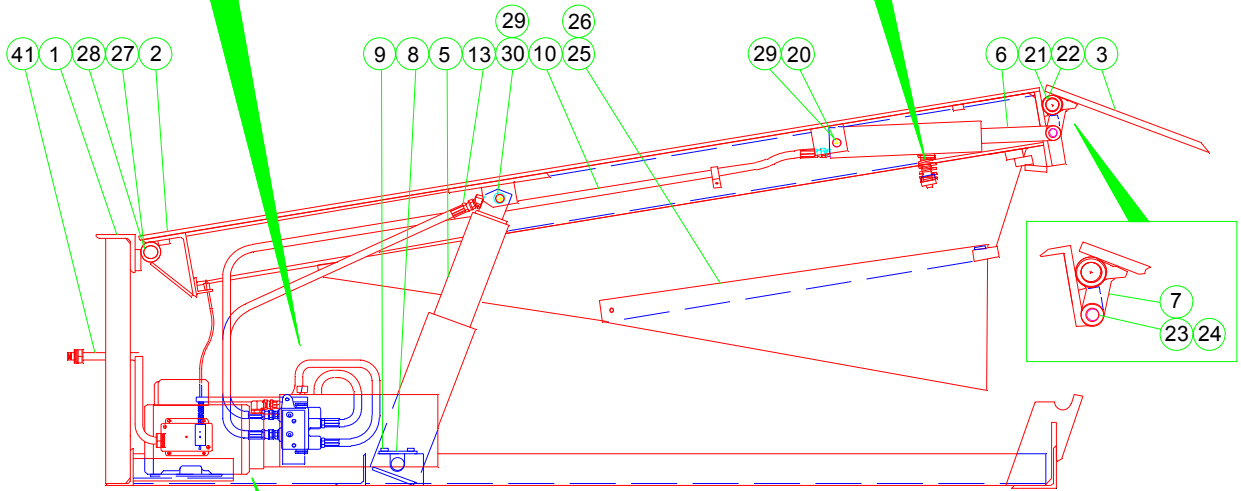
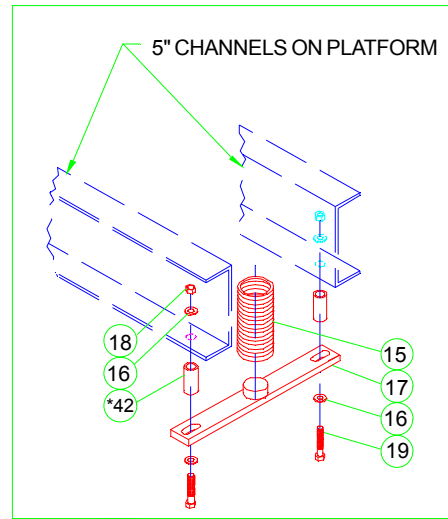
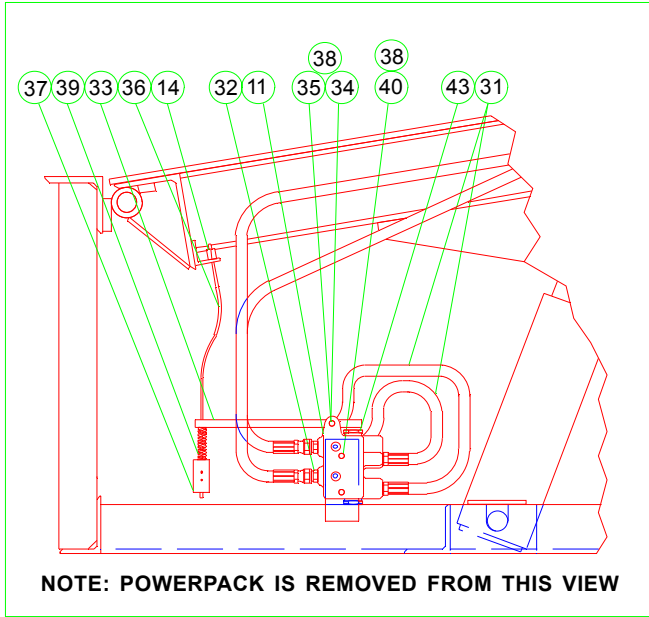

**CROSS SECTION OF DOCKLEVELER**

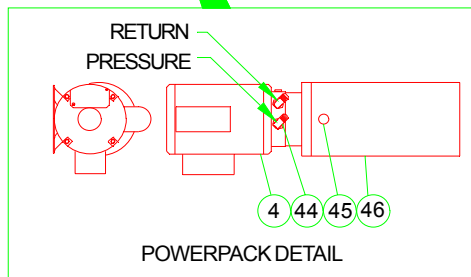

## PARTS LIST

ITEM	QTY.	PART NUMBER	DESCRIPTION
1	1	8435-_____	FRAME WELDMENT
2	1	9515-_____	PLATFORM WELDMENT
3	1	0595-_____	LIP WELDMENT
4	1	3411-0001	MOTOR 1 PHASE
	1	3411-0002	MOTOR 3 PHASE
5	1	0525-0044	HOIST CYL FOR 24" & 23-1/2" DEEP PIT
	1	0525-0043	HOIST CYL FOR 19-1/2" DEEP PIT
6	1	0525-0050	LIP CYLINDER - STD
	1	0525-0051	LIP CYLINDER - LONG
7	1	0522-0006	LIP LIFTER
8	2	7942-0001	HOIST CYLINDER - KEEPER
9	4	2101-0011	HHCS
	1	9904-0074	HYD. HOSE ASSY. 3/8 100R1 - LIP CYL. 6' LG.
10	1	9904-0075	HYD. HOSE ASSY. 3/8 100R1 - LIP CYL. 8' LG.
	1	9904-0076	HYD. HOSE ASSY. 3/8 100R1 - LIP CYL. 10' LG.
11	1	9575-0001	LOGIC BLOCK
12	2	9512-0024	TUBE - FILLER
13	1	9904-0078	HYD. HOSE ASSY. 3/8 100R1 - HOIST CYL. 6' LG.
	1	9904-0074	HYD. HOSE ASSY. 3/8 100R1 - HOIST CYL. 8' & 10' LG.
14	1	7952-0002	NICRO SLEEVE
15	1	0522-0002	SPRING - LIP CYLINDER
*16	2-12	2101-0060	FLAT WASHER
17	1	9455-0001	LIP CYLINDER HOLDDOWN
18	2	2101-0040	LOCKNUT
19	2	2101-0155	HHCS
20	1	9202-0004	PIN - LIP CYLINDER
21	1	9202-0003	PIN - LIP HINGE 6' WIDE
	1	9202-0014	PIN - LIP HINGE 6.5' WIDE
	1	9202-0006	PIN - LIP HINGE 7' WIDE
22	2	2101-0046	COTTER PIN
23	1	0522-0005	CLEVIS PIN
24	1	2101-0045	COTTER PIN
25	1	0015-_____	TOEGUARD ASSEMBLY - LEFT HAND SIDE
26	1	0015-_____	TOEGUARD ASSEMBLY - RIGHT HND SIDE
27	3	9202-0002	REAR HINGE PIN
28	6	2101-0047	COTTER PIN
29	4	2101-0049	CLIP HAIRPIN
30	1	9202-0005	PIN - HOIST CYINDER
31	2	9904-0006	HYD. HOSE ASSY - 3/8 100R1 - 24-1/2
32	2	9301-0143	STRAIGHT FITTING
33	1	5402-0007	OPERATOR LEVER
34	1	2101-0014	HEX HEAD CAPSCREW
35	7	2101-0039	LOCKNUT
36	1	7952-0001	CABLE
37	1	8102-0001	WEIGHT
38	7	2101-0163	WASHER
39	1	9572-0004	SPRING
40	2	2101-0015	HEX HEAD CAPSCREW
41	1	4305-0173	FLEX CONDUIT ASSEMBLY
*42	2	9452-0006	SPACER
43	1	9574-0001	SPOOL ASSEMBLY
44	2	9301-0116	90 DEGREE ELBOW
45	1	9301-0020	BREATHER CAP
46	1	9391-0008	POWERPACK

\* NOTE: FOR DOCKLEVELERS USING 5" CHANNEL, ITEM #16 QUANTITY IS 4 & ITEM #42 (QUANTITY OF 2) IS USED. FOR DOCKLEVELERS USING 6" CHANNEL, ITEM #16 QUANTITY INCREASES TO 12 AND ITEM #42 IS OMITTED.

## LIP CYLINDER

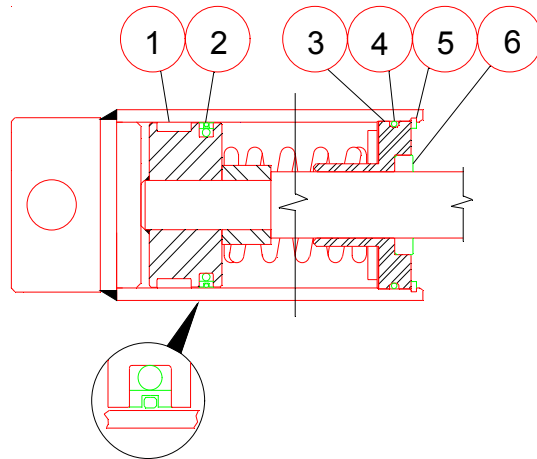

ITEM	QTY.	PART NUMBER	DESCRIPTION
1	1	0521-0109	WEAR RING
2	1	0521-0110	PISTON SEAL
3	1	0522-0087	CYLINDER HEAD
4	1	0521-0003	"O" RING
5	1	0521-0004	RETAINING RING
6	1	0521-0002	SEAL - ROD
7		0525-0059	SEAL KIT - INCLUDES ALL ABOVE

## HOIST CYLINDER

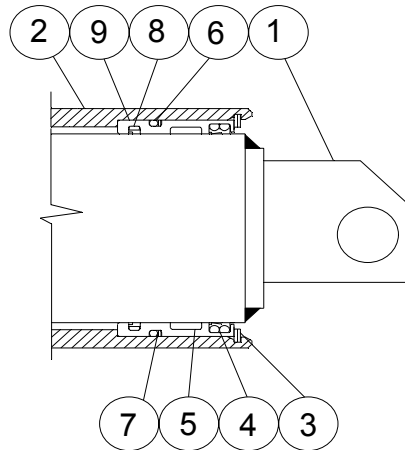

ITEM	QTY.	PART NUMBER	DESCRIPTION
1	1		PISTON WELDMENT
2	1		TUBE - WELD ASSEMBLY
3	1	0521-0013	RETAINING RING
4	1	0521-0105	EXCLUDER PLUS
5	1	0521-0103	SLYDRING
6	1	0521-0008	"O" RING
7	1	0521-0009	BACK-UP RING
8	1	0521-0104	STEPSEAL
9	1	0522-0120	GLAND - ALUMINUM
10		0525-0048	SEAL KIT - INCLUDES ALL ABOVE