

DLM

DOCK LEVELER
MANUFACTURING

C SERIES MECHANICAL

DOCK LEVELERS

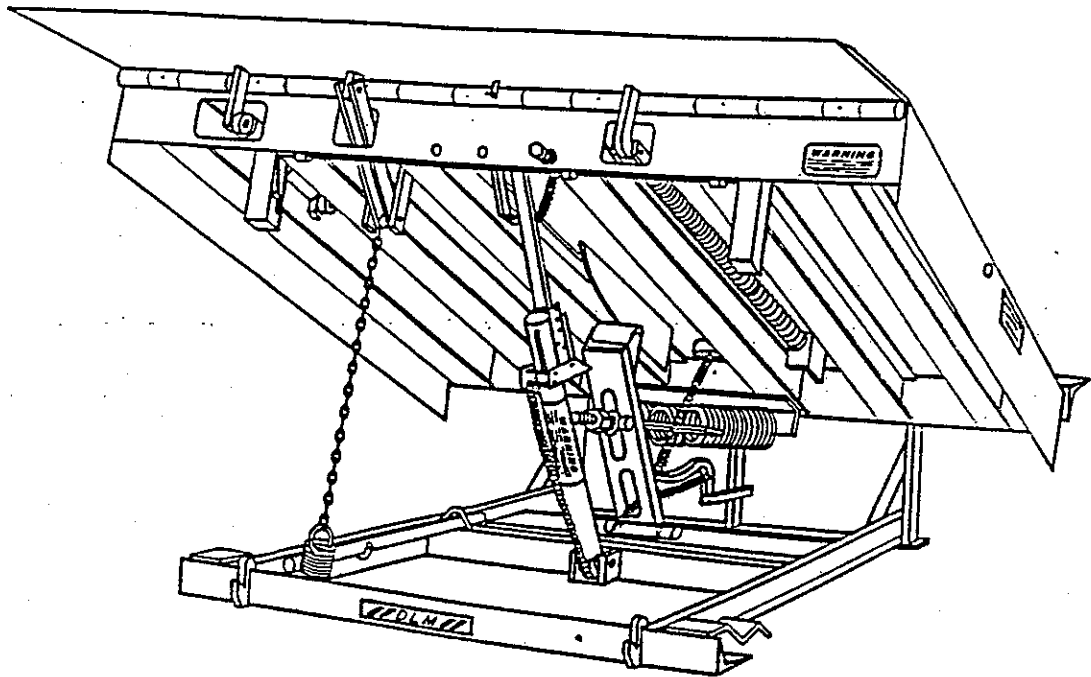

WARNING: Read and understand all warning and instructions before attempting to install or operate the leveler. Always use the maintenance strut when working under the open deck. Failure to observe these and other safe work habits may result in personal injury and/or property damage.

INSTALLATION AND OPERATING INSTRUCTION

C96 MECHANICAL



















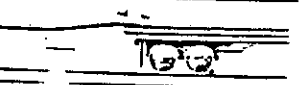

COPYRIGHT 1996 DLM, INC.

DLM

DOCK LEVELER
MANUFACTURING

GOOD SAFETY PRACTICES DOCK LEVELING DEVICES

LEARN THE SAFE WAY TO OPERATE THIS EQUIPMENT. READ AND UNDERSTAND THE MANUFACTURER'S INSTRUCTIONS. IF YOU HAVE ANY QUESTIONS, ASK YOUR SUPERVISOR.

	STAY CLEAR OF DOCK LEVELING DEVICE WHEN FREIGHT CARRIER IS ENTERING OR LEAVING AREA.	
	CHOCK / RESTRAIN ALL FREIGHT CARRIERS.	
	DO NOT USE A BROKEN OR DAMAGED DOCK LEVELING DEVICE.	
	DO NOT MOVE OR USE THE DOCK LEVELING DEVICE IF ANYONE IS UNDER OR IN FRONT.	
	KEEP HANDS AND FEET CLEAR OF PINCH POINTS.	
	LIP MUST REST SECURELY ON FREIGHT CARRIER BED.	
	DO NOT USE DOCK LEVELING DEVICE IF FREIGHT CARRIER IS TOO HIGH OR TOO LOW.	
	DO NOT OVERLOAD THE DOCK LEVELING DEVICE.	
	KEEP A SAFE DISTANCE FROM BOTH SIDE EDGES.	
	DO NOT OPERATE ANY EQUIPMENT WHILE UNDER THE INFLUENCE OF ALCOHOL OR DRUGS.	
	DO NOT LEAVE EQUIPMENT OR MATERIAL UNATTENDED ON DOCK LEVELING DEVICE.	

INSTALLATION INSTRUCTIONS FOR C-SERIES MECHANICAL DOCK LEVELER

Installation to be performed by qualified, experienced installation personnel. DLM, Inc does not install levelers and cannot be responsible for installation.

WARNING

Always use safe work habits.

WARNING: Read and understand all warnings and instructions before attempting to install or operate the leveler. Always use the maintenance strut when working under the open deck. Failure to observe these and other safe work habits may result in personal injury and/or property damage.

1. Check pit for proper construction. Clean out all debris. Make sure the walls of the pit are plumb and square. Measure dimensions shown in figure 1 and table 1, measure pit depth along a straight edge laid across the width of the pit 6 1/2 inches from the rear wall and 2 inches from the edge of the dock.

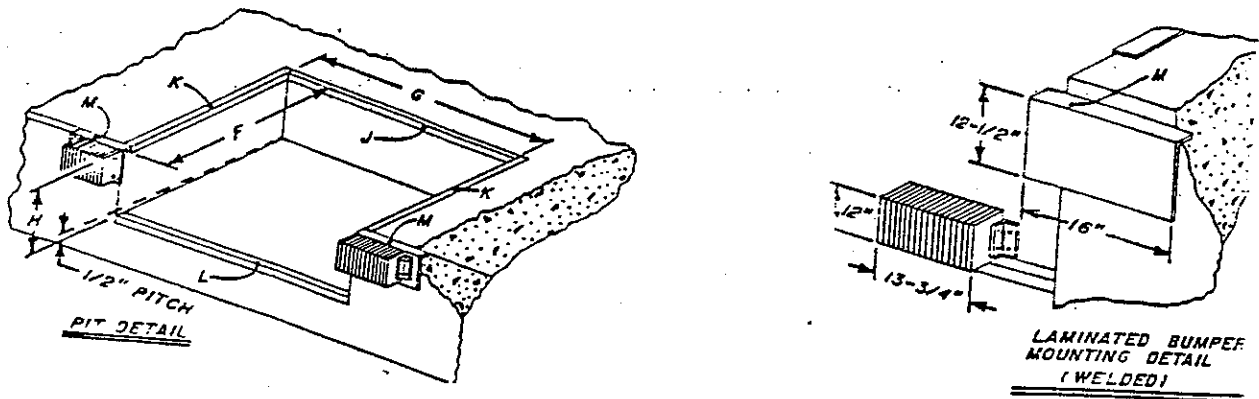

figure 1

TABLE 1

MODEL	C66	C68	C6.56	C6.58	C76	C78
F	.63.5"	87.5"	63.5"	87.5"	63.5"	87.5"
G	74"	74"	80"	80"	85"	85"
H	PIT DEPTH TO BE 19" AT REAR AND SLOPE 1/2" TO FRONT					
J	80"	80"	86"	86"	91"	91"
K	60.5"	84.5"	60.5"	84.5"	60.5"	84.5"
L	74"	74"	80"	80"	85"	85"
M	BUMPER PLATE 3" x 12-1/2" x 16"					

DLM

DOCK LEVELER MANUFACTURING

2. If any pit depth (p or q along the straight edge) is less than 18-5/8", chisel out depth. If pit depth is more than 18-5/8" it will be necessary to shim the difference.
3. It is very important to properly support the under structure of the leveler. The entire load moving across the leveler is supported at the load points. There are six load bearing areas on the under structure of the leveler. Three are located along the rear bottom plate directly beneath the three vertical posts, one is located under the lift arm pivot, and two along the front angle under the entire length of each safety leg/lip keeper support. Refer to figure 2 and figure 3.

Figure 2

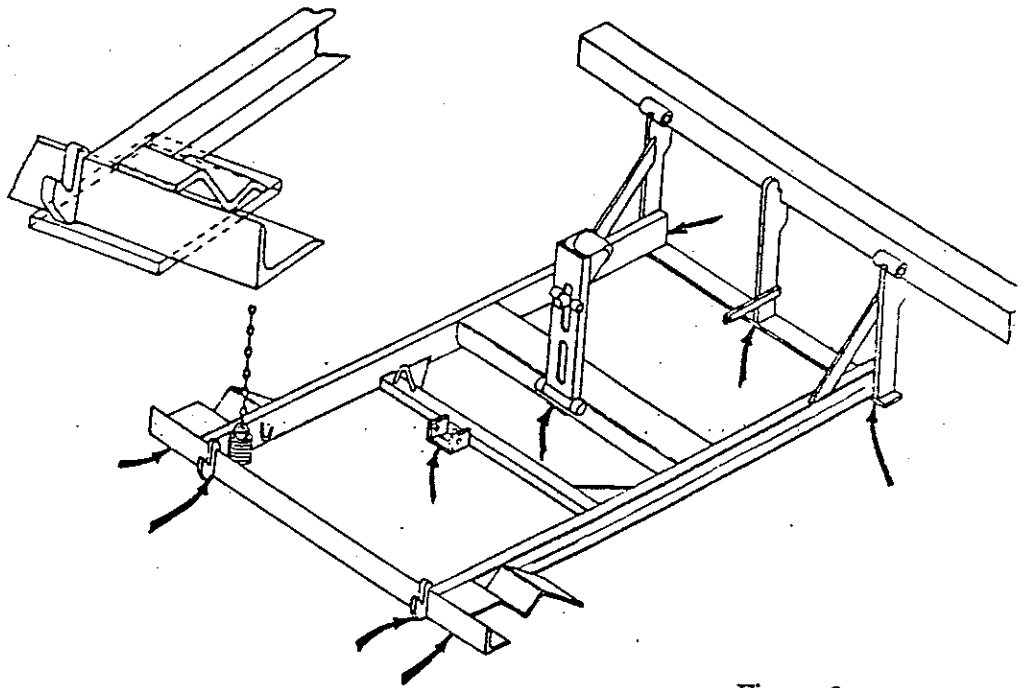

Figure 3

4. Remove the shipping straps from the front of the leveler.
5. Position leveler in pit. Install shims as necessary, at load points making sure all corners are flush with floor of building.
6. Once a flush fit is obtained all around the leveler, tack weld the two rear angles together. Refer to figure 4.

WARNING

Leveler should not be operated until rear angle of unit is welded to pit angle.

When working under the open board, use the maintenance strut.

7. Actuate the leveler by pulling and holding the release ring located in the recess at the rear of the leveler.
8. Make sure that the maintenance strut is securely in place before entering the area under the leveler.

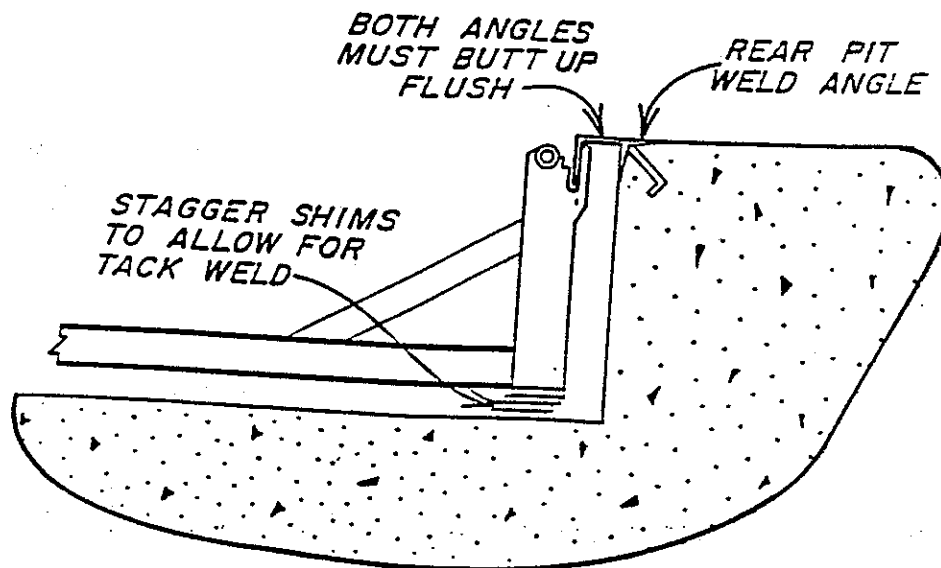

figure 4

9. Shim any remaining load bearing points and weld all shims securely to the under structure of the leveler to prevent shifting.
10. Weld the front angle of the under structure to the curb angle securely.
11. Finish welding the rear angle of the leveler to the rear curb angle. Six 6" long welds 6" apart are sufficient.
12. Check all load bearing points to make sure **ALL** shims are welded to under structure and the leveler is properly supported. Installation of the leveler is now complete. Please make sure that the bumpers are securely affixed to the building.

WARNING

Read and understand all warnings and procedures in the operating instructions before attempting to operate the leveler.

DLM

DOCK LEVELER MANUFACTURING

OPERATING INSTRUCTIONS FOR C-SERIES MECHANICAL DOCK LEVELER

WARNING

Do not operate the leveler while any equipment or personnel are standing on or in front of the leveler.

Do not activate the leveler until the truck is situated squarely against the bumpers and the truck's wheels are securely chocked.

Do not walk or drive any equipment on the leveler until all motion has stopped and the hinged lip rests securely on the bed of the truck.

Always return the dock leveler to the safe cross traffic position after unloading and/or loading operations are completed.

Never leave dock leveler unattended unless it is in the safe cross traffic position.

Never allow untrained personnel to operate the leveler.

Do not attempt to lift any part of the leveler by hand.

Always use safe work habits.

1. With the leveler in the stored position, position truck squarely against the dock bumpers. Make sure that the wheels of the truck are securely chocked before attempting to load or unload.

Never attempt to operate the leveler or any material handling equipment at a level or grade which exceeds the operating range of the equipment as specified by the manufacturer.

PERCENT OF GRADE dock/truck differential

	4"	6"	8"	10"	12"	14"	16"
d							
e	5'	8.7	13.1	17.5	21.9	26.2	-
c							
k							
l	6'	6.9	10.4	13.9	17.3	20.8	-
e							
n	8'	4.9	7.3	9.8	12.2	14.7	-
g							
t							
h	10'	3.8	5.7	7.6	9.5	11.3	13.2
							15.1

2. When unloading, be sure to keep leveler in the stored position until any extreme end load has been removed from the truck. If the truck bed is below dock level see step 7.
3. Actuate the leveler by pulling and holding the release ring located at the rear of the leveler until the deck rises fully and extends the lip.

WARNING

Never attempt to walk on unsupported hinged lip.

Do not attempt to walk on raised deck with anyone under the leveler or hinged lip.

Never release either operating ring until all deck motion has stopped.

-
- 4a. For above dock level trucks, simply walk out on the deck of the leveler. The deck of the leveler will begin to descend and come to rest when the hinged lip contacts the bed of the truck.
 - 4b. For below dock level trucks, retract the safety legs by pulling and holding ring located in the recess towards the front of the leveler. The leveler will come to rest when the hinged lip contacts the bed of the truck. The safety legs are reactivated upon the release of the ring.

WARNING

Never use forklift or any other material handling equipment to lower the leveler.

Should the leveler malfunction, keep all personnel and equipment away from the area and call your qualified service representative immediately.

-
5. With the hinged lip resting securely on the bed of the truck complete unloading and/or loading operations.
 6. To remove the leveler from the truck before the truck departs, actuate the leveler as in step 3 above, slowly walk the leveler down allowing enough time for the lip to fold completely, making sure that the lip rests securely in the keepers (safe cross traffic positions).

DLM

DOCK LEVELER MANUFACTURING

7. (With optional Below Dock Control) To replace or remove an end load below dock level, cycle leveler as in step 3 above, then slowly walk leveler down allowing enough time for the lip to fold completely, then deactivate the safety legs by pulling and holding the ring located in the front of the leveler. Allow the lip to miss lip keepers and lower to its full downward position.
8. Always make sure that the leveler is in safe cross traffic position and that the lip rests securely in the keepers before leaving the dock unattended.

LUBRICATION

1. Always follow all procedures and warnings in the operating instructions.
2. Set up lubrication procedures on a regular basis, approximately every three months.
3. Zerk fittings are provided on all grease applications.
4. **DO NOT** lubricate the ratchet bar or pawl on the hold down assembly.
5. While performing maintenance on leveler always inspect parts susceptible to damage caused by moving vehicles.

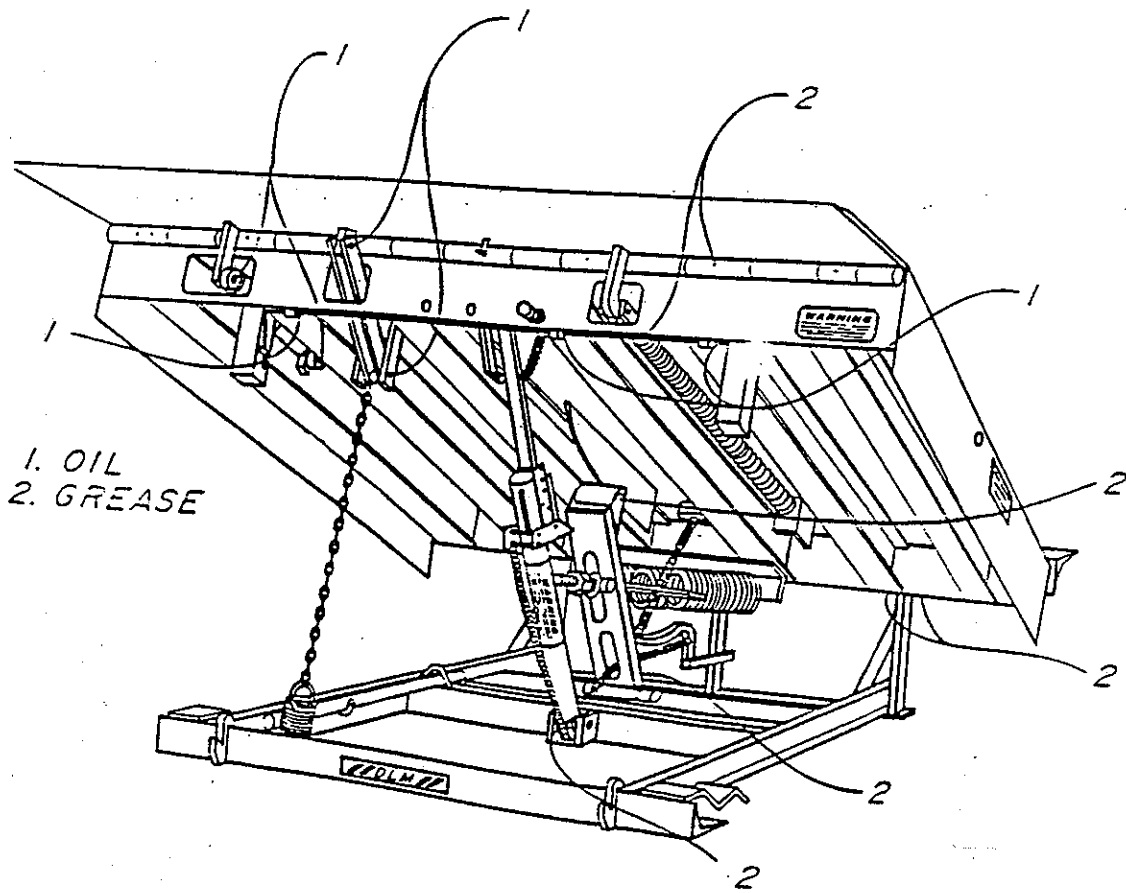
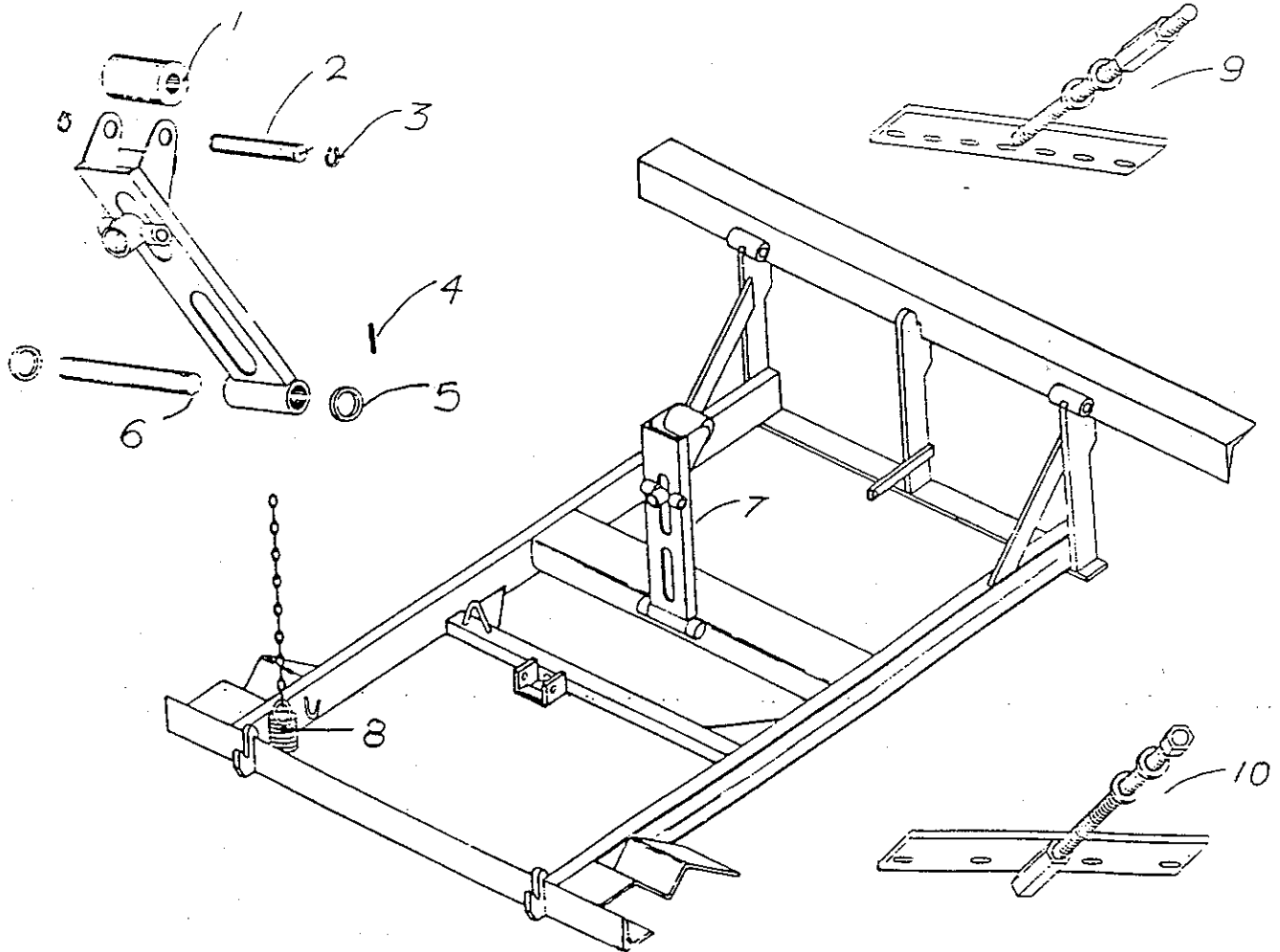

figure 5

UNDER STRUCTURE ASSEMBLY



ITEM	DESCRIPTION	MODEL	PART NUMBERS
1,2,3	C-LIFT ARM ROLLER ASSY	ALL	OTP-6419
4,5,6	C-LIFT ARM PIVOT ASSY	ALL	OTH-6443
7	LIFTARM ASSY SHORT 25"	ALL	OTP-6417
8	LEFT ARM ASSY LONG 27"	ALL	OTP-6418
9	SNUBBER SPRING	ALL	OTH-2555
10	T-BARS	ALL	OTH-6427
			OTH-6429

UNDER STRUCTURE ASSEMBLY

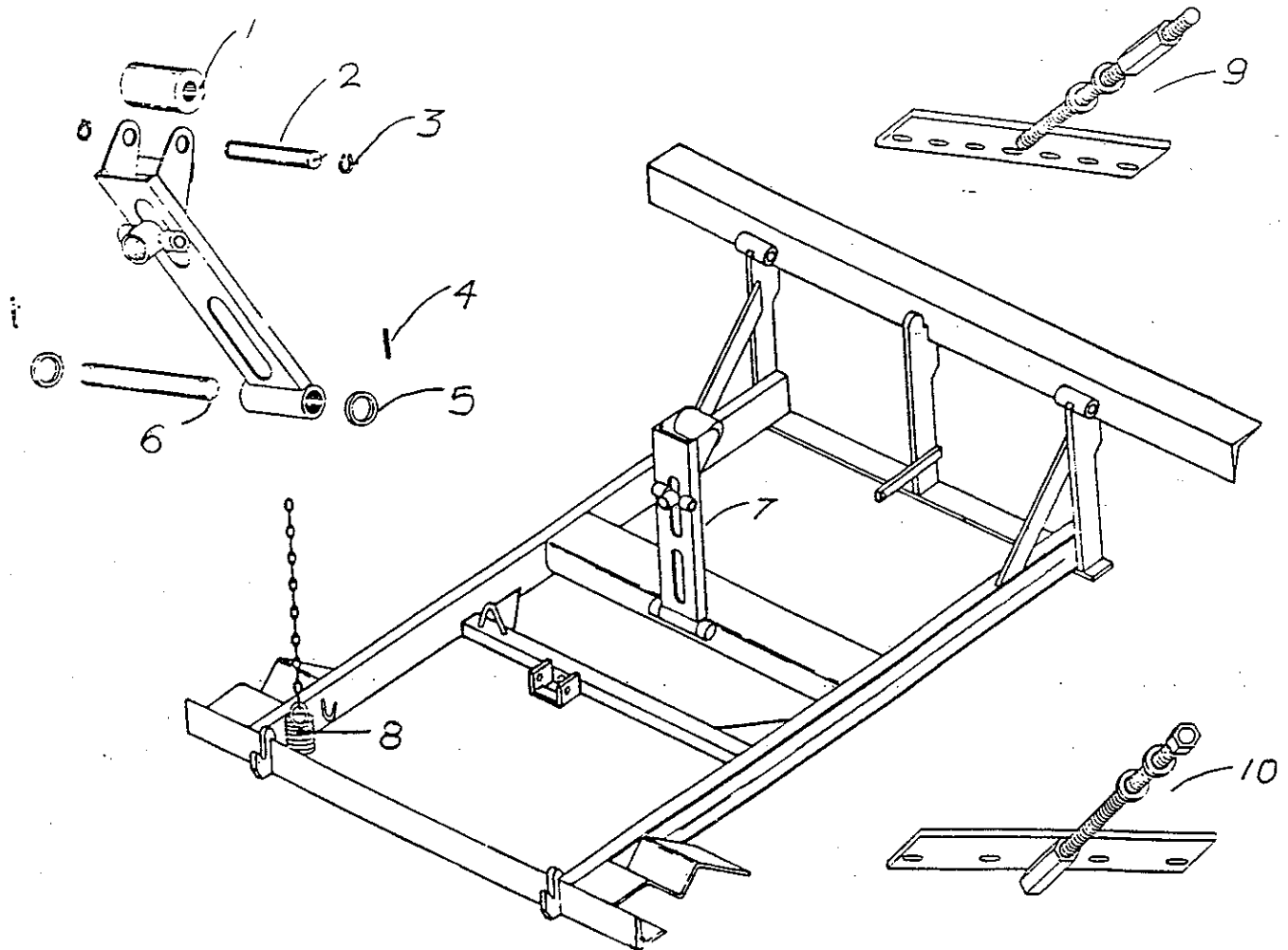

OLD STYLE

ITEM	DESCRIPTION	MODEL	PART NUMBERS
1,2,3	C-LIFT ARM ROLLER ASSY	ALL	OTP-6419
4,5,6	C-LIFT ARM PIVOT ASSY	ALL	OTH-6443
7	LIFTARM ASSY SHORT 25"		OTP-6417
	LIFT ARM ASSY LONG 27"		OTP-6418
8	SNUBBER SPRING		OTH-2555
9	T-BARS	ALL	OTH-6427
10			OTH-6429

DLM

**DOCK LEVELER
MANUFACTURING**

E-Z PULL RELEASE ASSEMBLY

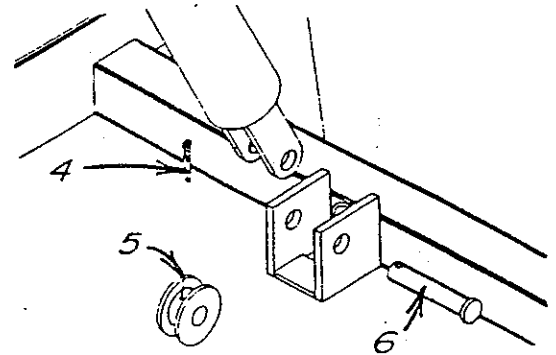
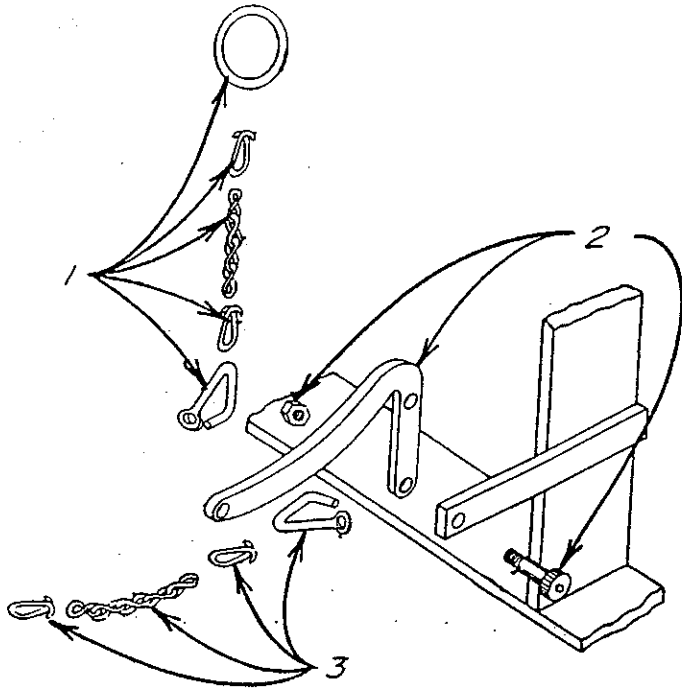

E-Z PULL RELEASE ASSEMBLY PARTS

ITEM	DESCRIPTION	MODEL	PART NUMBERS
1	E-Z PULL CHAIN ASSEMBLY	19in	OTP-6920
		23in	OTP-6929
2	E-Z RELEASE ARM ASSEMBLY	ALL	OTP-6930
3	HOLD DOWN RELEASE CHAIN ASSY	6ft	OTP-6922
		8ft	OTP-6923
4	COTTER PIN	ALL	OTH-2374
5	CHAIN ROLLER	ALL	OTH-2405
6	CLEVIS PIN	ALL	OTH-2356

HOLD DOWN ASSEMBLY OTP-2563

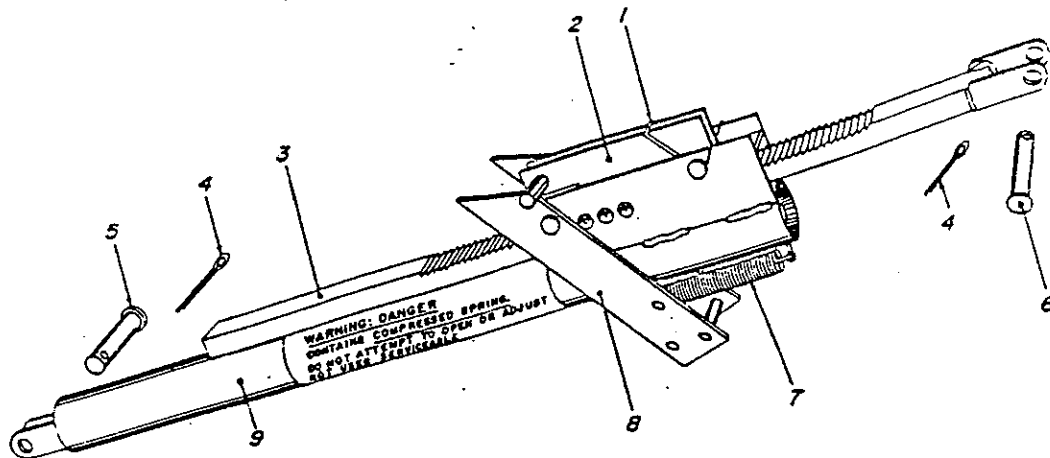

WARNING: Danger
Contains compressed spring.
Do not attempt to open or adjust.
Not User Serviceable.

HOLD DOWN ASSEMBLY PARTS

ITEM	DESCRIPTION	MODEL	PART NUMBER
1	PAWL SPRING		
2	PAWL ASSY		OTH-2556
3	RATCHET BAR		
*	RATCHET BAR & PAWL ASSEMBLY (must be replaced as a set)		OTH-2575
4	COTTER PIN		
5	CLEVIS PIN		OTH-2374
6	CLEVIS PIN		OTH-2356
7	RELEASE ARM SPRING		OTH-2355
8	RELEASE ARM		OTH-2559
9	FLOAT ASSEMBLY		OTH-2569 OTH-2565

DLM

DOCK LEVELER
MANUFACTURING

DECK ASSEMBLY

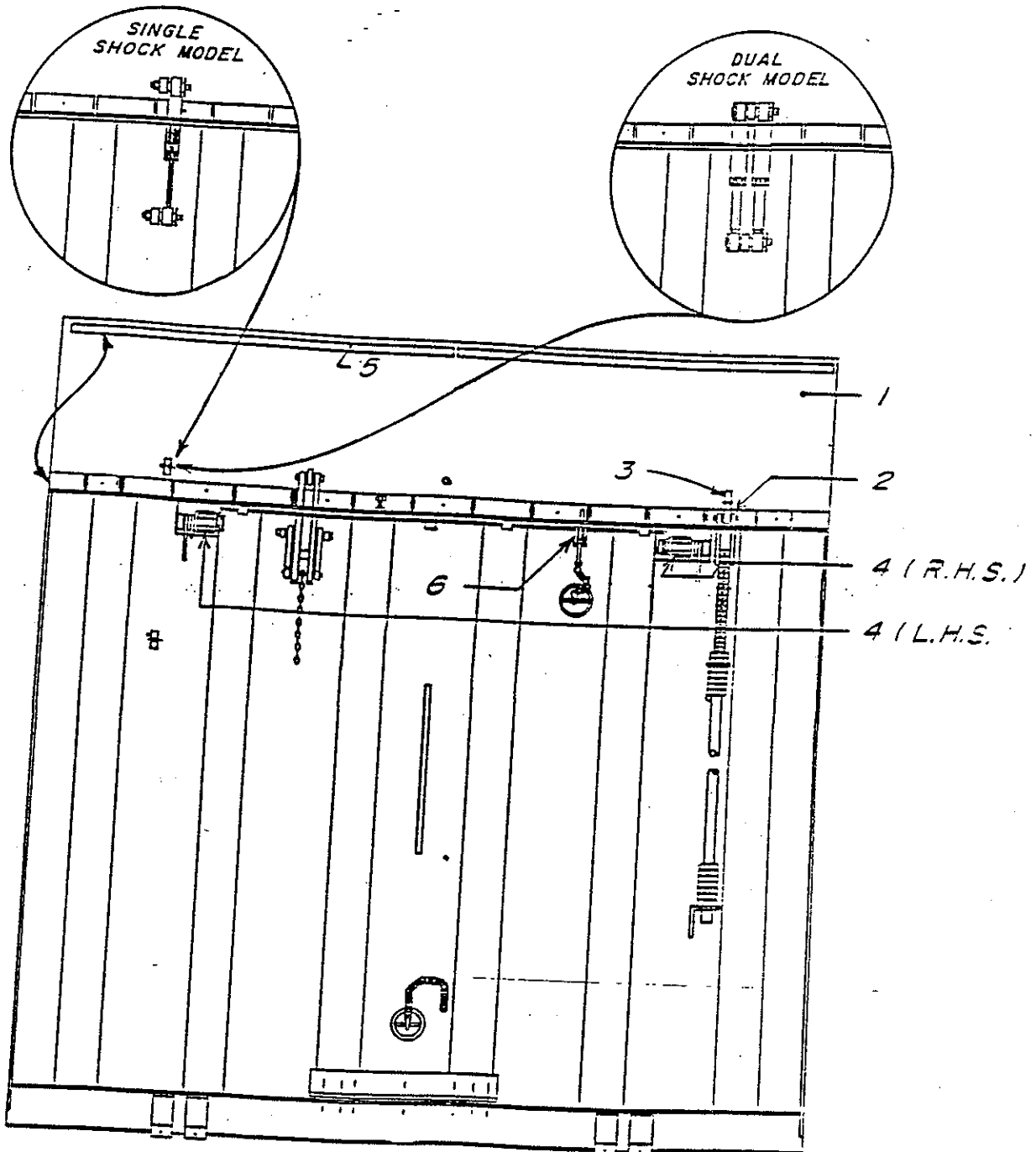

DECK ASSEMBLY

ITEM	DESCRIPTION	MODEL	PART NUMBERS	
1	LIP PLATE ASSY	6FT x 16IN	25K OTH-6260	
			30K OTH-6261	
		6FT x 18IN	35K OTP-6240	
			25K OTH-6262	
		6FT x 20IN	30K OTH-6263	
			35K OTP-6241	
		6.5FT x 16IN	25K OTH-6496	
			30K OTH-6497	
		6.5FT x 18IN	35K OTP-6242	
			25K OTH-6264	
		6.5FT x 20IN	30K OTH-6265	
			35K OTP-6243	
		7FT x 16IN	25K OTH-6266	
			30K OTH-6267	
		7FT x 18IN	35K OTP-6244	
			25K OTH-6498	
		7FT x 20IN	30K OTH-6499	
			35K OTP-6248	
		2	LIP ASSIST ASSY	25K OTH-7096
				30K OTH-7097
3	LIP ASSIST PIVOT	35K OTP-7240		
		25K OTH-7098		
4	SAFETY LEG ASSY	30K OTH-7099		
		35K OTP-7241		
5	LIP HINGE PIN ASSY	25K OTH-7173		
		30K OTH-7174		
6	SAFETY LEG CONTROL ASSY	35K OTP-7242		
		16-18IN OTH-6682		
		20IN OTH-6683		
			SEE PAGE 14	
		6FT OTH-6450		
		6.5FT OTH-6451		
		7FT OTH-7162		
		ALL SEE PAGE 16		

DLM

DOCK LEVELER
MANUFACTURING

LIP ASSIST

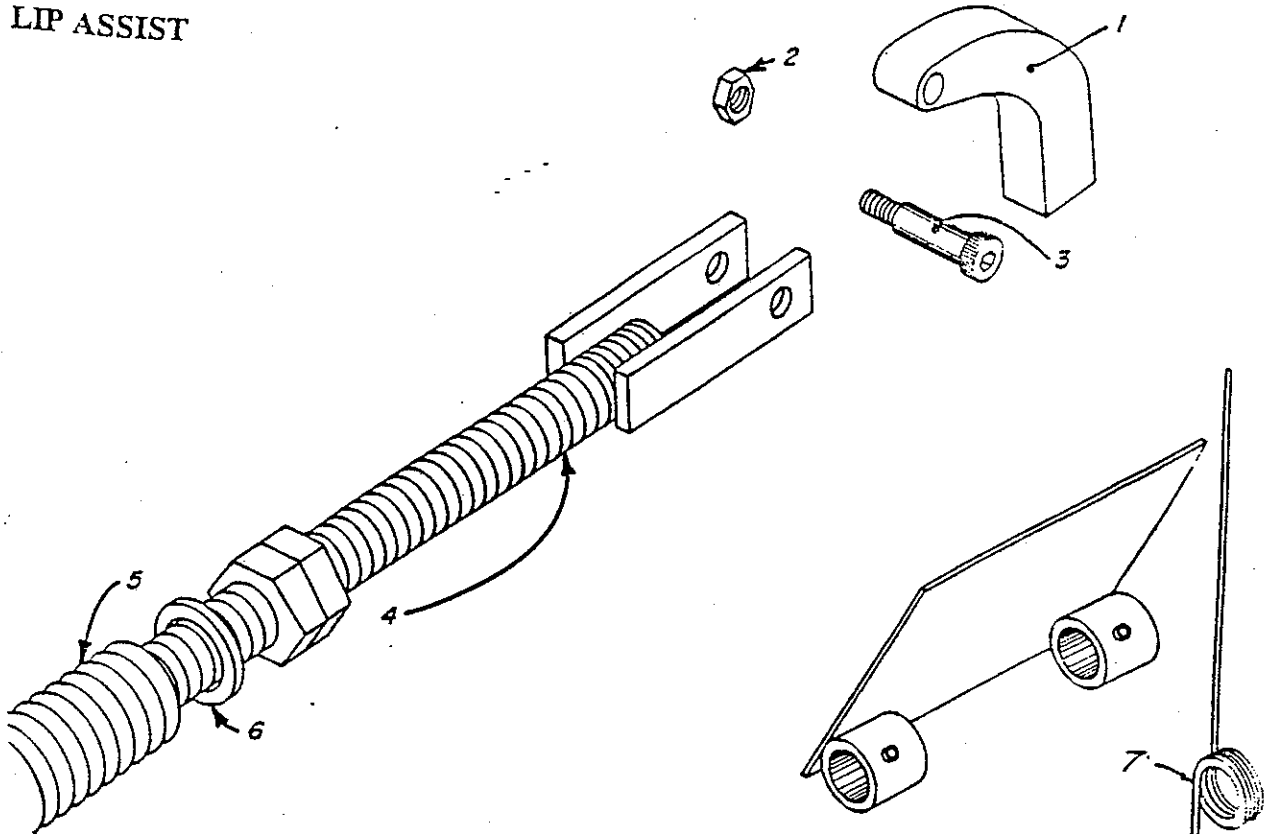

SAFETY LEG ASSY

8 (L.H.S.)
9 (R.H.S.)

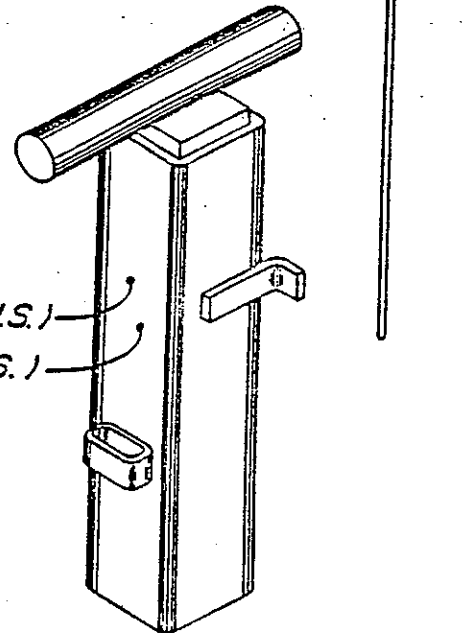

REAR HINGE PIN ASSY

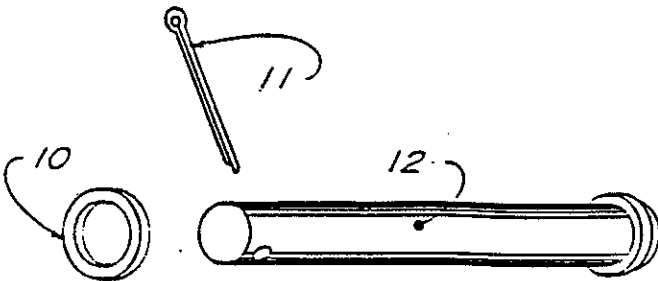

DLM

DOCK LEVELER MANUFACTURING

LIP ASSIST ASSY

ITEM	DESCRIPTION	MODEL	PART NUMBERS
1	LIP CLEVIS	16-18IN 20IN	OTH-6682 OTH-6683
2	LOCK NUT	ALL	OTH-2131
3	SHOULDER BOLT	ALL	OTH-2061
4	LIP ASSIST ROD	16-18IN 20IN	OTH-6406 OTH-6405
5	LIP ASSIST SPRING	16-18IN 20IN	OTH-2550 OTH-2552
6	WASHER	16-18IN 20IN	OTH-2222 OTH-2218
SAFETY LEG ASSY			
7	SAFETY LEG SPRING	ALL	OTH-2557
8	LEFT SIDE SAFETY LEG ASSY	ALL	OTH-6231
9	RIGHT SIDE SAFETY LEG ASSY	ALL	OTH-6232
REAR HINGE PIN ASSY			
10	WASHER		OTH-6441
11	COTTER PIN	ALL	OTH-2218
12	REAR HINGE PIN	ALL	OTH-2376 OTH-3442

DLM

DOCK LEVELER
MANUFACTURING

SAFETY LEG CONTROL ASSY

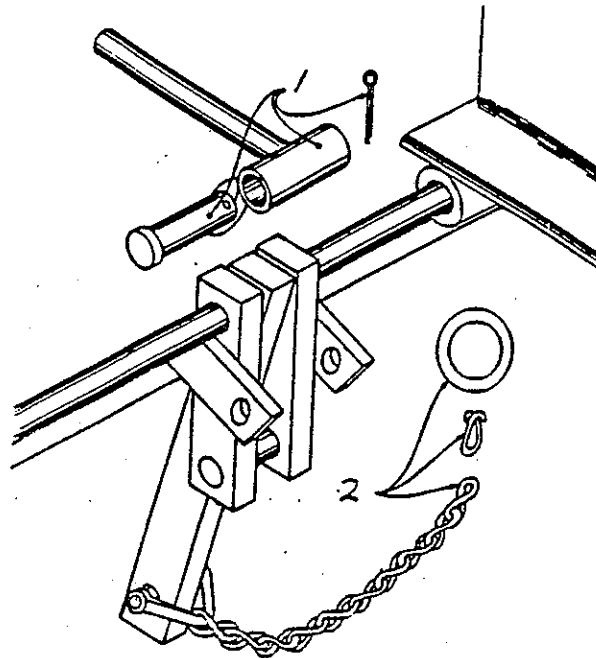

ITEM	DESCRIPTION	MODEL	PART NUMBERS
1	BDC PUSH ROD ASSY		OTP-6646
2	SAFETY LEG PULL CHAIN		OTH-6234

LB ASSY

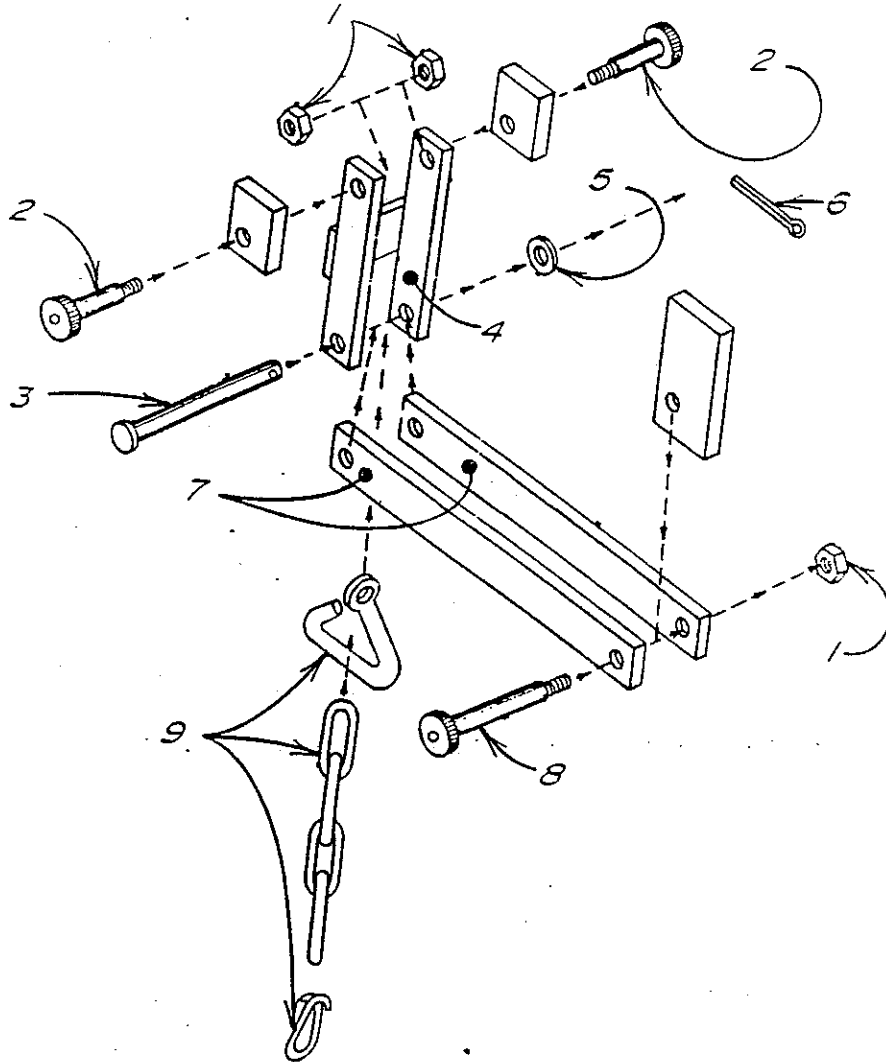

ITEM	DESCRIPTION	MODEL	PART NUMBERS
1	LOCK NUT		
2	SHOULDER BOLT		OTH-2131
3	CLEVIS PIN		OTH-2060
4	LB LINKAGE ASSY		OTH-2364
5	FLAT WASHER		OTH-6409
6	COTTER PIN		OTH-2210
7	LB BAR		OTH-2374
8	SHOULDER BOLT		OTH-6930
9	SNUBBER CHAIN		OTH-2061 OTH-6834

DLM

DOCK LEVELER
MANUFACTURING

SINGLE SHOCK ASSY
OTH-6465

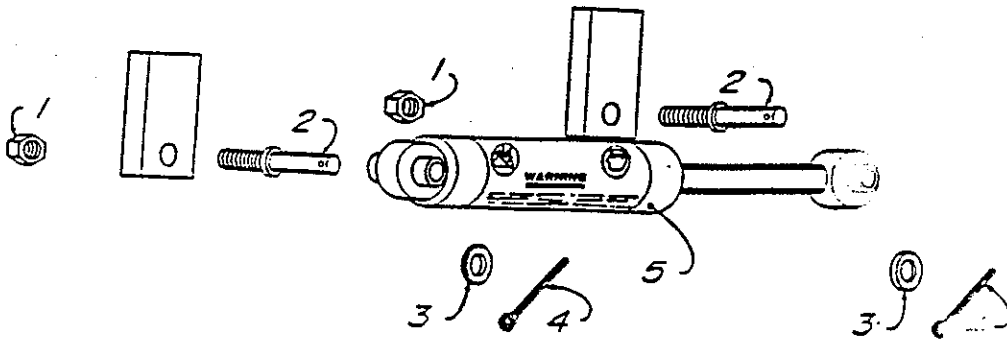

ITEM	DESCRIPTION	MODEL	PART NUMBERS
1	LOCK NUT		
2	CLEVIS BOLT		OTH-2163
3	FLAT WASHER		OTH-2351
4	COTTER PIN		OTH-2210
5	GAS SHOCK ABSORBER		OTH-2374 OTH-2582

DUAL SHOCK ASSY
OTH-6433

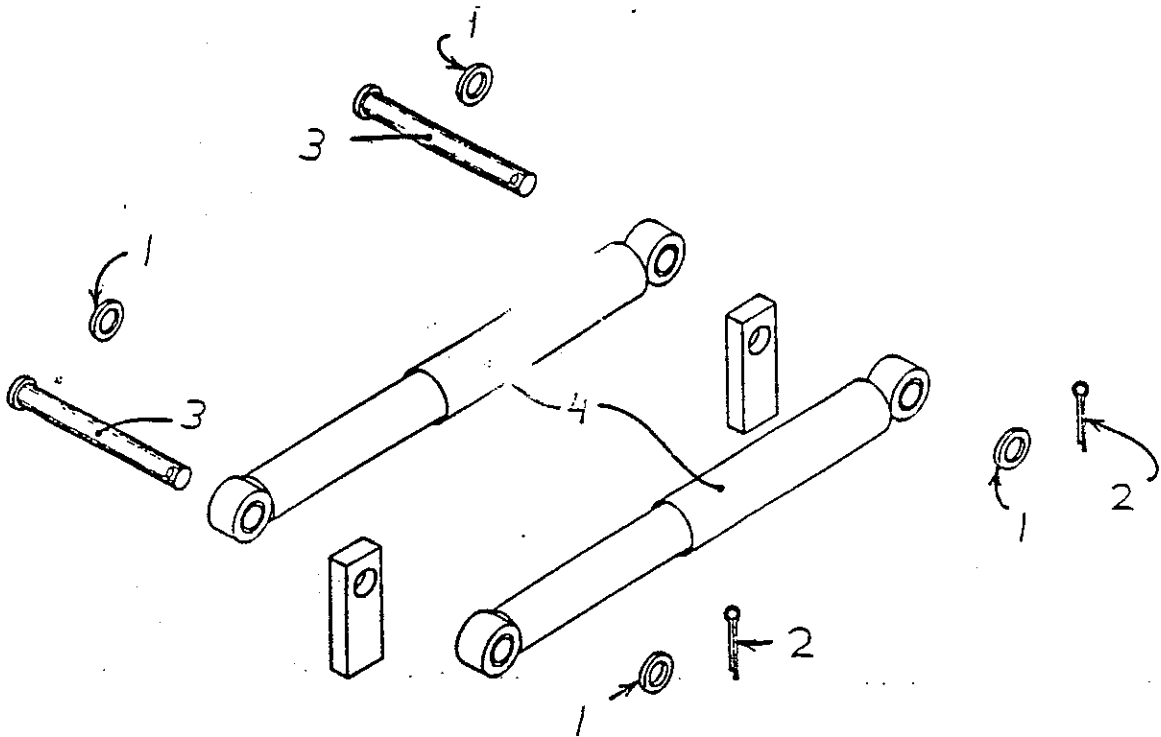

ITEM	DESCRIPTION	MODEL	PART NUMBERS
1	FLAT WASHER		OTH-2210
2	COTTER PIN		OTH-2374
3	CLEVIS PIN		OTH-2369
4	SHOCK ABSORBER		OTH-2580

DLM

DOCK LEVELER MANUFACTURING

TROUBLESHOOTING

PROBLEM	CAUSE	SOLUTION
Deck does not rise or rises slowly	<ol style="list-style-type: none"> 1. Detached or broken release cable. 2. Deck or weatherseal binding against wall. 3. Insufficient main spring tension. 4. Damaged or worn hold down assembly. 	<ol style="list-style-type: none"> 1. Replace or reconnect cable. 2. Trim seal or chip concrete away. 3. Increase tension on main springs. 4. Clean and inspect hold down.
Lip does not extend.	<ol style="list-style-type: none"> 1. Lip assist chain detached or broken. 2. Insufficient lip counterbalance force. 3. Insufficient main spring tension. 	<ol style="list-style-type: none"> 1. Replace or reconnect chain. 2. Increase lip counterbalance force. 3. Increase tension on main springs.
Not able to walk down deck.	<ol style="list-style-type: none"> 1. Excessive main spring tension. 2. Damaged or worn hold down assembly. 	<ol style="list-style-type: none"> 1. Reduce tension on main springs. 2. Clean and inspect hold down assembly.
Lip falls too fast for normal walk down.	<ol style="list-style-type: none"> 1. Insufficient lip counterbalance force. 2. Detached, worn or broken shock. 	<ol style="list-style-type: none"> 1. Increase lip counterbalance force. 2. Inspect shock, reconnect or replace as necessary.
Deck does not stay down.	<ol style="list-style-type: none"> 1. Release chain fouled. 2. Dirt fouling teeth on ratchet bar. 3. Detached or broken hold don pivot pins. 4. Damaged or worn hold down assembly. 	<ol style="list-style-type: none"> 1. Unfoul chain 2. Clean teeth, <u>DO NOT LUBRICATE RATCHET BAR.</u> 3. Replace pivot pins. 4. Clean and inspect hold down assembly.
Lip does not descend after truck departs.	<ol style="list-style-type: none"> 1. Excessive lip counterbalance force. 2. Unlubricated lip hinge. 	<ol style="list-style-type: none"> 1. Decrease lip counterbalance force. 2. Grease hinge spools.

DLM, Inc. prides itself in offering a truly superior dock leveler at an affordable price. Our dedication to quality is represented in carefully engineered and efficient designs, superior welding and attention to details that ensure years of rugged service. For continued reliability use only genuine DLM replacement parts, this will insure the structural integrity of the leveler. Please lubricate your DLM dock levelers, exercise common sense in the use and operation of the levelers and observe safe work habits.

DLM, Inc. warrants that its products will be free from defects in design, materials and workmanship for a period of one year from date of shipment. All claims for breach of this warranty must be made within thirty days after the defect is or can, with reasonable care, be detected, and in no event more than 395 days after shipment. To be entitled to the benefits of this warranty, the product must have been properly installed, maintained, operated within its rated capacity and not otherwise abused. This warranty is DLM, Inc.'s exclusive express warranty.

In the event of any defects covered by this warranty, DLM, Inc. will remedy such defects by repairing or replacing any parts found to be defective. This warranty is limited to parts only and does not include labor to remove, replace, install or adjust the product. This shall be the exclusive remedy for all claims whether based on contract, negligence, or strict liability. DLM, Inc. shall not in any event be liable for any loss of the use of any equipment or incidental or consequential damages of any kind.

DLM, Inc. expressly disclaims all implied warranties including the implied warranties of merchantability and fitness.

DLM
DOCK LEVELER
MANUFACTURING